

Installation and Maintenance Manual for the Afridev Handpump

REVISION 2 - 2007

This manual has been prepared to cover installation and maintenance aspects of the Afridev Handpump.

This document results from several years of work carried out by Water & Sanitation Program (WSP) in partnership with SKAT – RWSN (former HTN), NGO's, handpump field workers and the private sector in several countries.

The experience gained in recent years has been incorporated into this Specification.

This Manual is intended to assist all users of the Afridev Handpump, especially to give a guideline for the installation procedure and also for preventive maintenance.

Suggestions for improvements and requests for further information are welcome, and should be sent to SKAT at the address given below.

First edition: SKAT - HTN Publication, 1995

Revised edition: 2-2007 by Karl Erpf,

Drawings: SKAT, St.Gallen,

Photographs: Meera & Ceiko Pumps Ltd. Hyderabad, India, and SKAT, St.Gallen,

Copyright: SKAT - RWSN
Provided the source SKAT - RWSN is acknowledged, extracts of this publication may be reproduced.

Distribution: SKAT
Vadianstrasse 42
CH-9000 St.Gallen
Switzerland

Phone: +41 71 228 54 54

Fax: +41 71 228 54 55

E-mail: info@skat.ch

or karl.erpf@skat.ch

URL: <http://www.skat.ch> and <http://www.rwsn.ch>

Installation and Maintenance Manual for the Afridev Handpump

Contents

	Page No.
1.0 Background of the Afridev Handpump Development	4
2.0 Pump Features and Options	4
3.0 Pump Features and Options	9

Part 1 Installation of the Afridev Handpump

4.0 Platform Construction	10
4.1 General Comments	10
4.2 Selection of Platform Type	12
4.3 Material required for Platform Construction	17
4.4 Preparation for Grouting the Platform for a Borehole	18
4.5 Grouting the Platform	20
4.6 Curing of Platform	23
4.7 Hard Core Layer and Fencing of Platform	24
4.8 Soak pit	24
4.9 Disinfecting the Well	25
5.0 Preparation for Handpump Installation	26
5.1 Decision on correct Cylinder Setting Depth	26
5.2 Materials and Tools required for Installation of “Down Hole Components”	28
5.3 Preparation of “Down Hole Components”	28
5.4 Important Information for Jointing PVC-U Pipes	31
5.5 Preparation of “Above Ground Components”	32
6.0 Handpump Installation Sequences	33
6.1 Installation of “Down Hole Components”	33
6.2 Installation of “Above Ground Components”	38

Part 2 Maintenance of the Afridev Handpump

7.0 Preventive Maintenance	45
7.1 Preventive Maintenance Checks of Handpump	45
7.2 Maintenance of Pump Surrounding	46
8.0 Maintenance of Handpump	47
8.1 Diagnosis of Handpump Problems	47
8.2 Tools and Spare Parts required for Handpump Maintenance	47
8.3 Procedure of Dismantling “Above Ground Components”	47
8.4 Dismantling Threaded Pumprods	48
8.5 Re-installing of Threaded Pumprods	48
8.6 Dismantling Hook & Eye Pumprods	49
8.7 Re-installing Hook & Eye Pumprods	49
8.8 Dismantling and Re-installing FRP Pumprods	50
8.9 Re-assembling “Above Ground Components”	50
9.0 Repair of Handpump	51
9.1 Removal of the Rising main	51
9.2 Repair of the Rising main pipe	53
9.3 Fishing of Dropped Handpump Parts	55
10.0 Recording of any Intervention	55

Annexes:

- I. Trouble Shooting Chart for AFRIDEV Handpumps,
- II. List of Spare Parts for AFRIDEV Handpumps,
- II. Replacement Interval of AFRIDEV Wearing Parts,
- IV. Correct Storage of AFRIDEV Handpump Components,
- V. Examples for recording of any Intervention,
- VI. Drawings of Fishing Tools for dropped Handpump Parts,
- VII. Technical Drawings of Repair Sockets,

Installation and Maintenance Manual for the Afridev Handpump

1.0 Background of the Afridev Handpump Development

The Afridev started life in Malawi in early 1981. From the start, the aim was to produce a deep well handpump that was very easy to maintain at village level and could be manufactured in countries like Malawi, where industrial resources are limited. The Maldev pump head went into production in early 1982, and was a significant step forward in head design, with the users' needs given first priority.

Early in the field-testing of Maldev pumps, the ball bearings caused problems and the first Afridev pump head, which uses plastic bearings, was installed in Malawi in late 1982. Major efforts to resolve the "bearing problem" continued up to early 1985, when a plastic bearing design was finalised.

The focus of Afridev development shifted to Kenya in early 1983, although testing continued in Malawi. Important contributions were being made by field workers in several East African countries, as well as by experts from organisations in Europe, who provided specialist advice or laboratory testing facilities. International handpump design meetings were held in Kenya in late 1984 and early 1986, and throughout this period design and testing of pump heads, cylinders, rods and rising mains continued. At all times, the primary objectives were absolute simplicity of maintenance, and minimum quality control requirements to simplify manufacture.

Plastics research and development has played a vital role in the success of this project, of which the outcome is the Afridev pump system.

The Afridev Handpump is manufactured in several developing countries in Africa & Asia. It is demonstrating that village men and women can maintain deep well handpumps, can be locally produced and can still be affordable and reliable.

2.0 Pump Features and Options

In the following pages you will find an overview of the pump features and the options available

Revision 5-2007

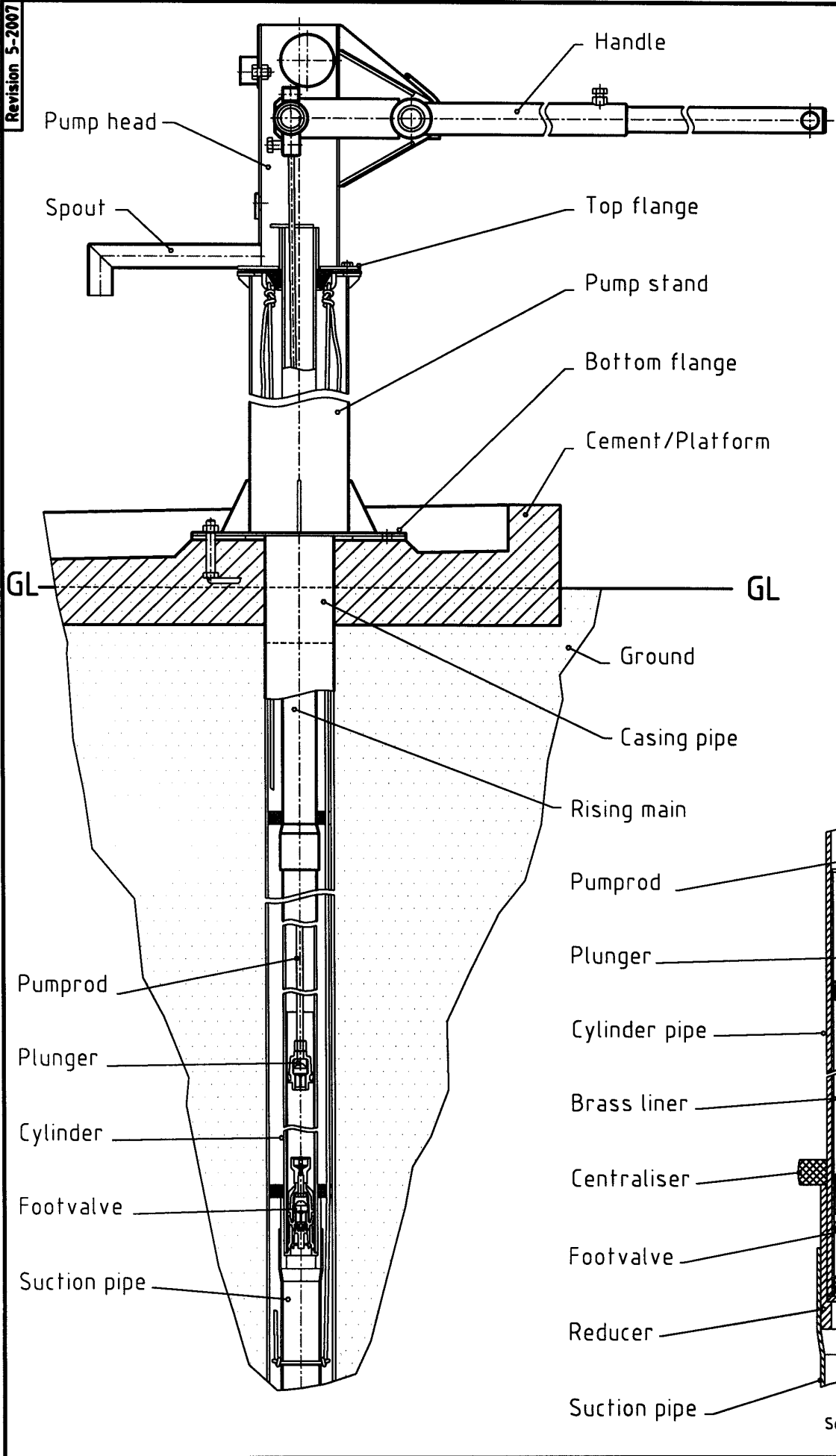

Rural Water Supply Network RWSN International Handpump Specification	Afridiv Pump assembly	Scale: 1 : 10 (1:5)	Drawn by: K. Erpf 13.07.01 Checked by: 02.03.07 Released by: 07.03.07	D9055
---	---------------------------------	----------------------------------	---	--------------

Scale 1 : 5

Afridev Handpump

List of options available for this pump type.

Options	A	B	C	D
Pump head type	Pump head with short spout: (30 cm) drawing No. B2003	Pump head with long spout: (58 cm) drawing No. B2003	---	---
Pump stand type	Pump stand with bottom flange: drawing No. B2055	Pump stand with 3 legs: drawing No. B2050	---	---
Rising main arrangement	PVC-U Rising main with "Sockets": drawing No. A2119	PVC-U Rising main with "Bell ends": drawing No. A2099	---	---
Cylinder arrangement	Brass plunger and Brass footvalve: drawing No. A2296	Brass plunger and Plastic footvalve: drawing No. A2257	Plastic plunger and Plastic footvalve: drawing No. A2070	---
Pumprod arrangement	MS- Pumprods, threaded connectors: drawing No. A2206	SS- Pumprods, threaded connectors: drawing No. A2209	FRP- Pumprods, Brass connectors: drawing No. A5889	SS- Pumprods, "Hook & Eye" conn. drawing No. A2110

Explanations:

- * not any longer recommended
- ** not recommended when PH value is < 6.5

Abbreviations:

PVC-U	Polyvinyl Chloride (unplasticized)
MS	Mild Steel
SS	Stainless Steel
FRP	Fibre Reinforced Plastic

Example:

Possible composition of a selected Afridev Handpump:

Pump head type	B
Pump stand type	C
Rising main arrangement	A
Cylinder arrangement	A
Pumprod arrangement	C

For more clarification see the following 3 pages!

Pump head types

(approx. scale = 1 : 10)

Option: A

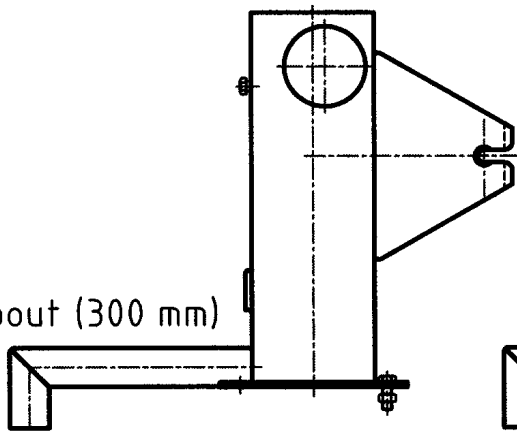

Short spout (300 mm)

Option: B

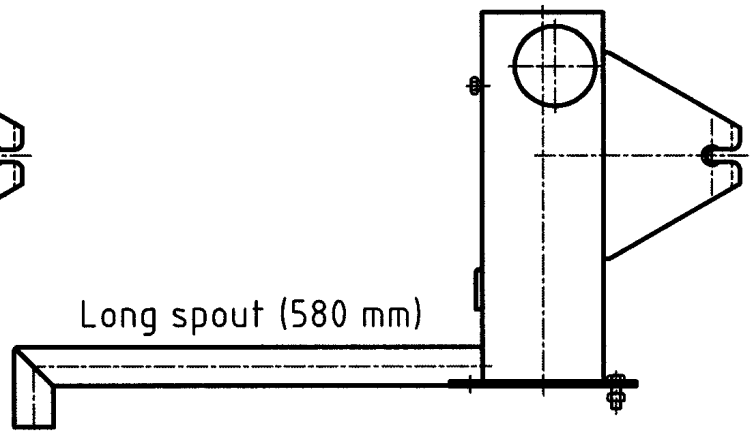

Long spout (580 mm)

Pump stand types

(approx. scale = 1 : 10)

A

Options:

B

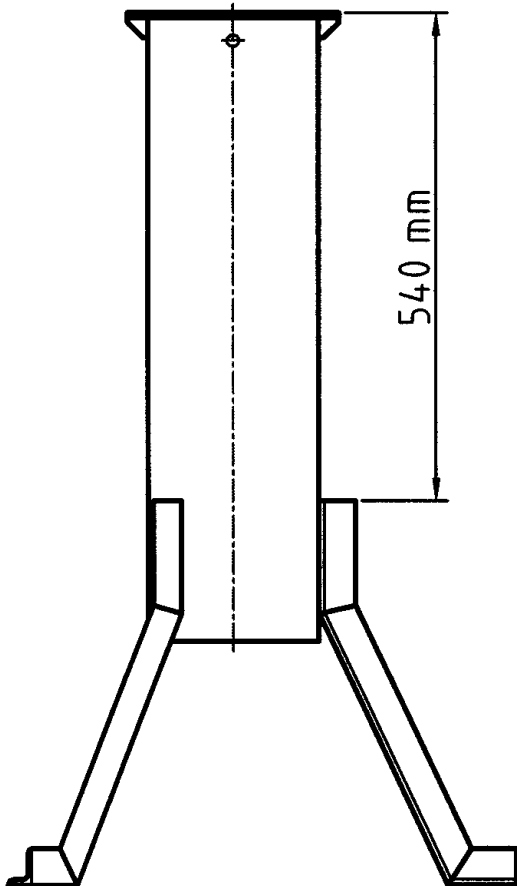

540 mm

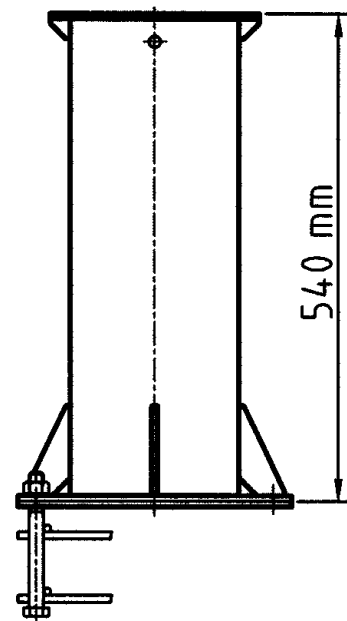

540 mm

Both stand types can be used for casing pipes up to 6 "

Rising main arrangements

(approx. scale = 1: 10)

IMPORTANT
State applicable
Centraliser size
for Casing used

- 4"
- 4.5"
- 5"
- 6"

PVC-U Riser pipes
(with bell-ends)
are available in
2.9 m lengths

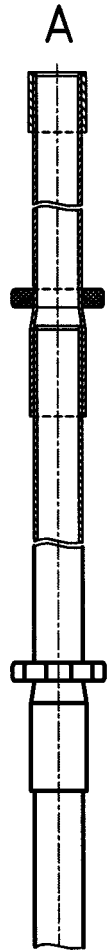

Options:

IMPORTANT
State applicable
Centraliser size
for Casing used

- 4"
- 4.5"
- 5"
- 6"

PVC-U Riser pipes
(pipes / sockets)
are available in
3 m lengths

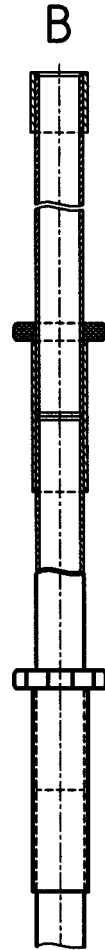

Plunger / Footvalve arrangements

(approx. scale = 1: 5)

A

Options:

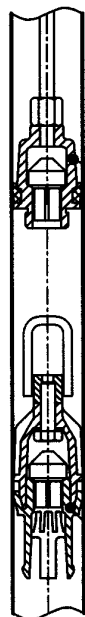

Brass Plunger

Plastic Footvalve
+ Fishing connector

Plastic Footvalve
+ Eye assembly

B

Options:

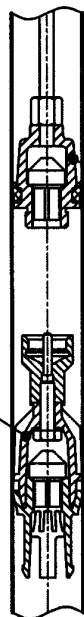

Brass Plunger

Brass Footvalve

C



Pumprod arrangements

(approx. scale = 1 : 5)

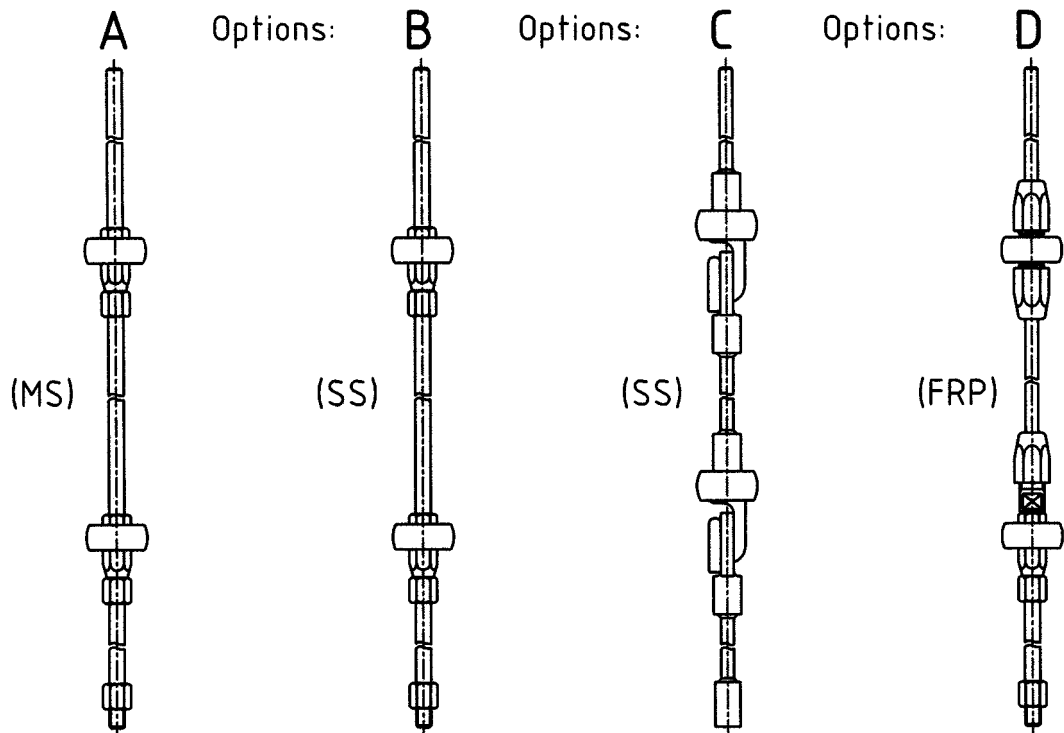

Options A,B and C are available in 3 m lengths - Option D in 3 or 6 m lengths

3.0 Supporting Documents

- Afridev Handpump Specification, Revision 5-2007,
- Afridev Injection Moulding Guidelines, Revision 1-1999,
- Moulding Guidelines for the Production of Rubber Components, Revision 1-1999,
- Rubber Moulds for Afridev Components, Edition 2003,
- Guidelines for Quality Control & Quality Assurance of Afridev Hp., Revision 1-2000,

Part 1 Installation of the Afridev Handpump

4.0 Platform Construction

4.1 General Comments

Sustained safe drinking water supply and sanitation facilities are essential to improve the living conditions of the rural population. The provision of safe water helps to combat water borne diseases and improves community health in general. Benefits of a safe water supply can reach far beyond considerations of public health and have a positive influence on the general well being, economic status and quality of life in a community.

4.1.1 Protection of Water Source

If a well site is chosen and the well drilled (or dug) into the ground at a site which is elevated and away from water logged areas during the rainy season, the water which percolates from an underground aquifer into the well should be pure enough to drink.

However, a water point obviously attracts a great deal of human contact. This is a potential source of contamination and should be protected against. The safety measures are as follows:

4.1.2 Well Siting

- The well should be in an elevated place, so that during the rainy season the water will run away from it, rather than into it.
- It should be at least 40 meters away from a latrine and uphill of the latrine.
- It should be at least 30 meters away from a cattle kraal, and uphill of the kraal.
- It should be well away from any depressed area in the ground, such as hollows that are used for rubbish tipping, hollows that are used for brick making or any other areas where water might collect.

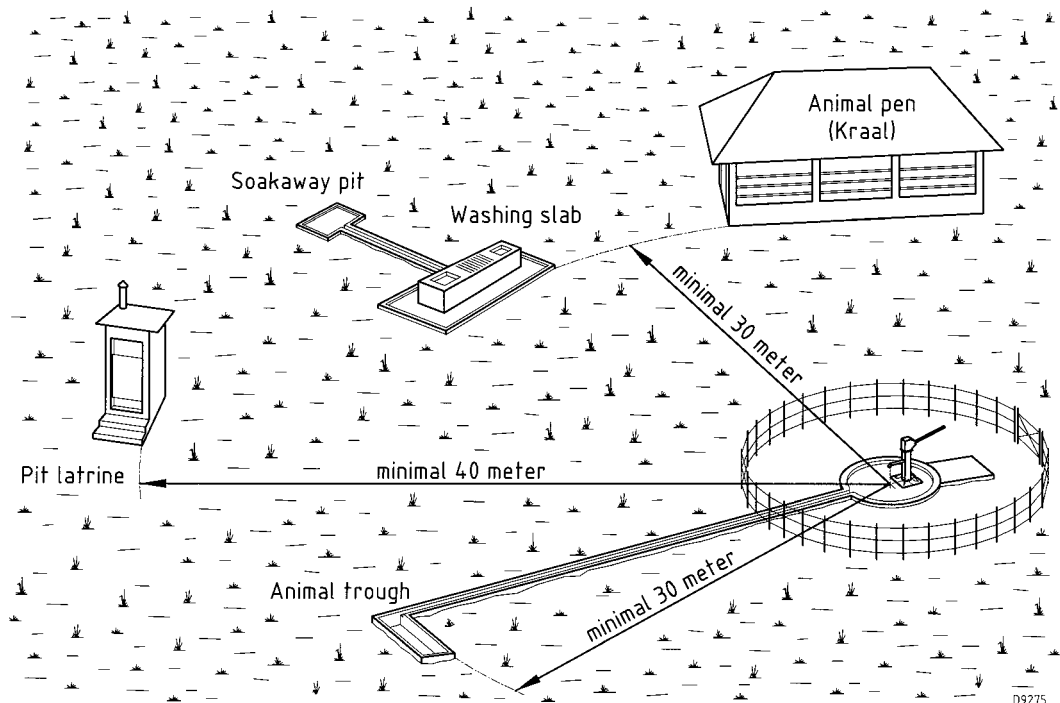

D9275

4.1.3 Hygiene Education and Water Supply

Throughout the water supply process, it is vital to bear in mind the important linkages between health, hygiene education and water. An awareness of the intimate relationships between these factors should be made clear to all water users.

Before the arrival of a new or improved water supply system, the water users of a village should receive hygiene training with regard to the collection, storage and use of water. For example, the transmission of diseases through contaminated water may not be understood in the community.

Cleanliness in the area of the water point is an important factor in the overall impact of the introduction of a new or improved facility.

If the surrounding area is not kept clean and free of animals, debris, waste and stagnant water, the water point could become a hub for the transmission of many infectious diseases.

In this respect, the ability of the community to manage the system and ensure regular cleaning of the water point is vital.

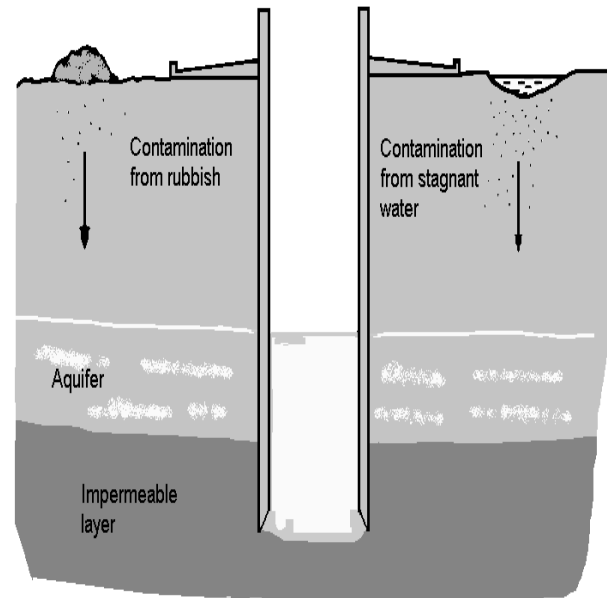

4.1.4 Platform Design

If the area around a well is allowed to become dirty, and waste and stagnant water is allowed to accumulate, it will become a source of infection for the users. Standing in bare feet in stagnant water or mud is a serious health risk in the tropics since the open water provides an ideal breeding ground for many types of parasite and/or disease carrier. Awareness of the direct links between hygiene and water must start at the collection point, otherwise the possible benefits from an improved water supply will be lost.

The construction of a platform (or slab) at the wellhead is an important contribution to the general hygiene in a community. In addition to discouraging the accumulation of stagnant water at the surface, the slab will help to prevent the contamination of the well through the infiltration of dirty water back into the aquifer.

The following points are important:

- a) The slab surrounding the water point should be made as wide as possible from properly made reinforced concrete of good quality. The water outlet (spout) should be placed in the centre of the slab, so that it collects the spill water, which then can run away through the drainage channel.

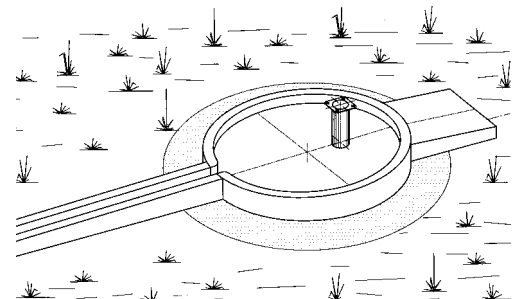

- b) All surfaces should slope towards the drainage channel and the edges of the slab should be raised.
- c) The slab should be well reinforced with steel wire, to prevent cracking. Dirty water can pass through cracks in a poorly constructed slab and contaminate the well beneath.

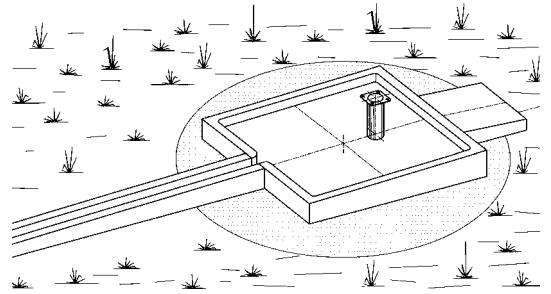

The shape of the slab is not as important as its capacity to drain water away from the well as quickly as possible and to ensure wastewater dispersal in a hygienic manner.

Where possible, the drain can lead to an area of vegetation, such as banana plants or a vegetable garden. If this is not an option, a soak-pit can be built or a trough for watering livestock can be provided.

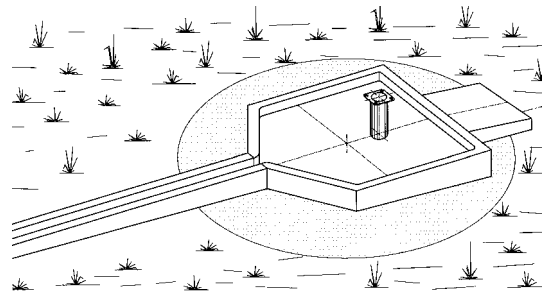

It is important that construction of the slab does not commence until the soil around the well, which was disturbed by the construction activities, has had an opportunity to settle properly.

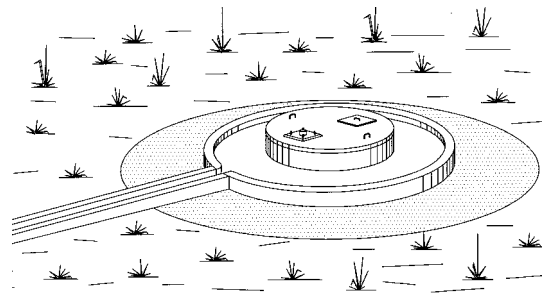

4.2 Selection of Platform Type

Consultation with the community is a must before a decision is taken on the platform layout. In the following three pages you will find typical platform designs for handpumps installed on boreholes or on dug-wells. These are indicative layouts and can be modified to suit communities' needs, which may include the following:

- a) Facilities for washing clothes,
- b) Facility for bathing,
- c) Trough for cattle watering,
- d) Collection of water for small-scale irrigation etc.

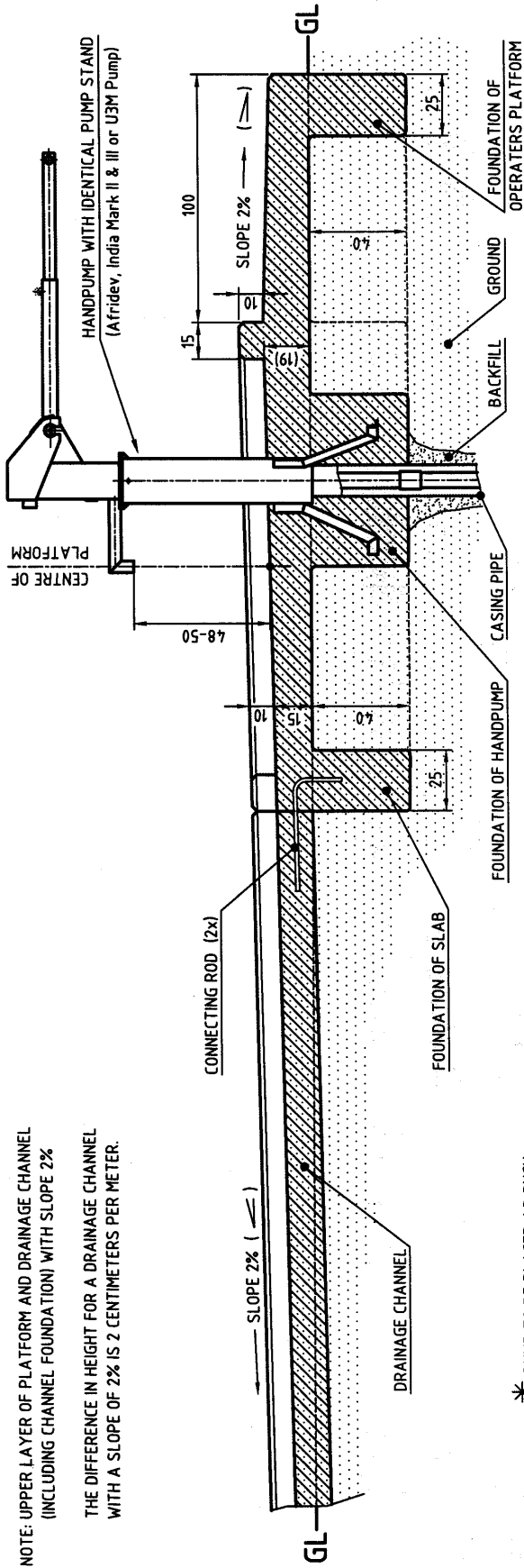

NOTE: UPPER LAYER OF PLATFORM AND DRAINAGE CHANNEL (INCLUDING CHANNEL FOUNDATION) WITH SLOPE 2%

THE DIFFERENCE IN HEIGHT FOR A DRAINAGE CHANNEL WITH A SLOPE OF 2% IS 2 CENTIMETERS PER METER.

* PUMP TO BE PLACED AS SUCH THAT THE WATER OUTLET (SPOUT) IS IN THE CENTRE OF THE PLATFORM. (NORMALLY 35 CENTIMETERS)

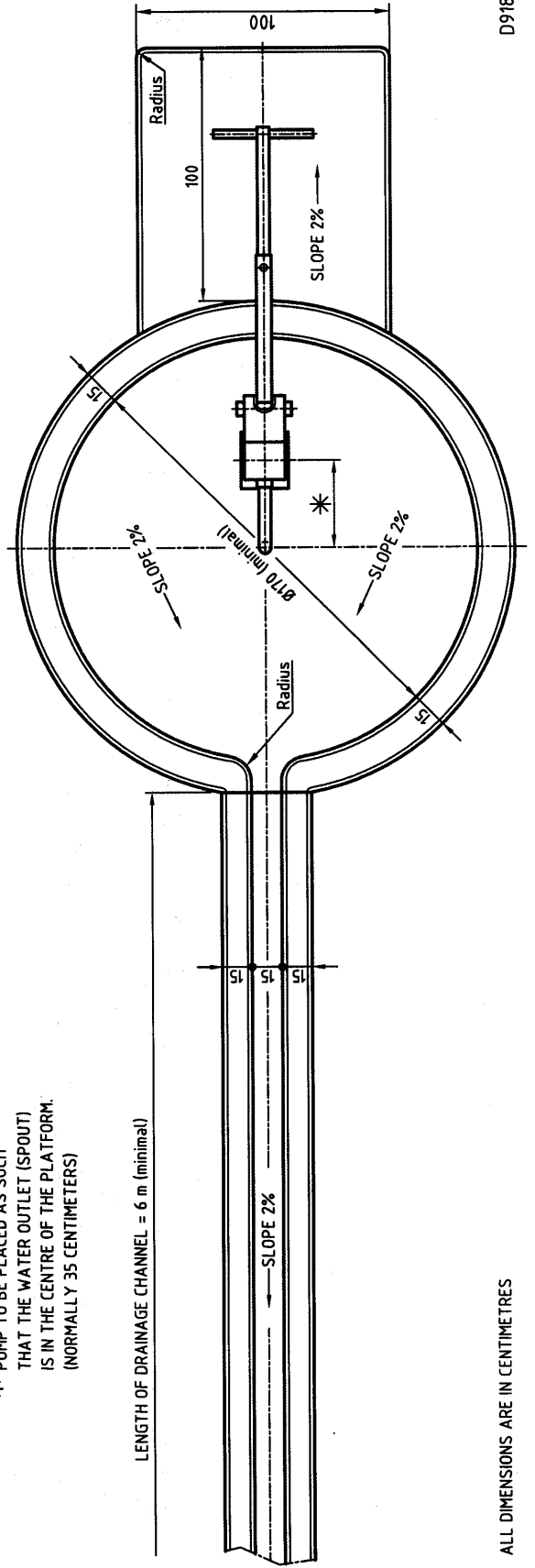

LENGTH OF DRAINAGE CHANNEL = 6 m. (minimal)

ALL DIMENSIONS ARE IN CENTIMETRES

D9186

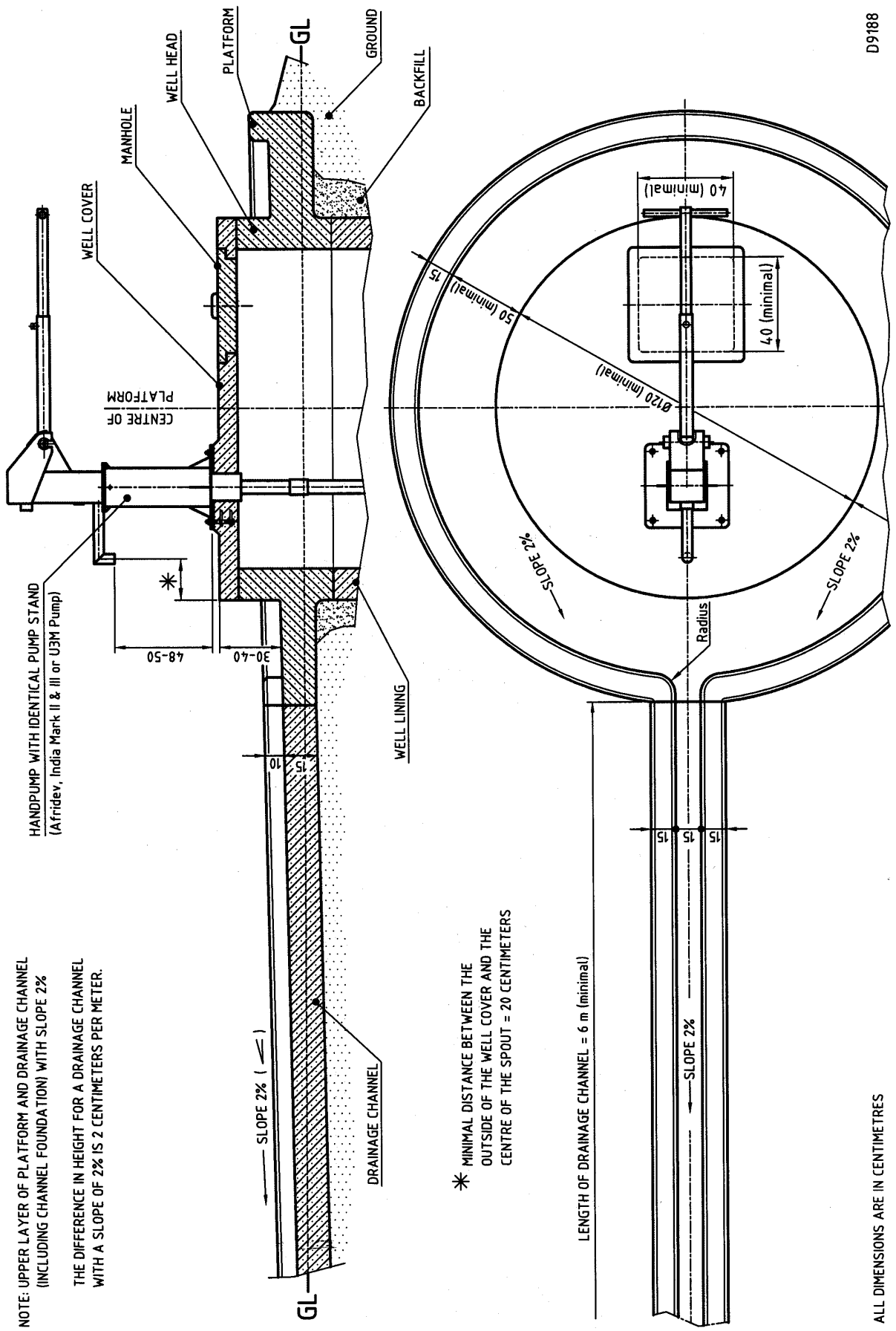

NOTE: UPPER LAYER OF PLATFORM AND DRAINAGE CHANNEL (INCLUDING CHANNEL FOUNDATION) WITH SLOPE 2%

THE DIFFERENCE IN HEIGHT FOR A DRAINAGE CHANNEL WITH A SLOPE OF 2% IS 2 CENTIMETERS PER METER.

* MINIMAL DISTANCE BETWEEN THE OUTSIDE OF THE WELL COVER AND THE CENTRE OF THE SPOUT = 20 CENTIMETERS

LENGTH OF DRAINAGE CHANNEL = 6 m (minimal)

ALL DIMENSIONS ARE IN CENTIMETRES

4.2.1 Fencing of Water Source

In addition to constructing a slab, it is important to erect a good fence around the water point. This can be done immediately after the construction of the well is finished, and should give enough space to operate the handpump. The advantages of fencing are that it serves to define quite clearly, for the whole community, the area of the well and it keeps animals away from the wellhead. In some cases, it may be necessary to have a gateway to keep out smaller animals such as dogs and goats.

The fencing can be made of suitable local materials like wood or stones. Problems of replacement and repair can be avoided altogether, by using a living hedge as fencing. Whatever type of fencing is used, it is important that access by the well users is guaranteed.



4.3 Material required for Platform Construction

4.3.1 Recommended Masonry Tools for Platform Construction

Item	Approx. Quantity
Shovel /Scoop	3 nos
Spade	1 no
Pick or Crow bar	2 nos
Mason's trowel	2 nos
Levelling plank (0.5 and 2 m)	1 each
Rubber bucket (for concrete)	4 nos
Steel bucket (for water)	2 nos
Measuring tape (3 m)	1 no
Spirit level	1 no
Platform shuttering (Steel form or wooden material)	1 no
Tamper sticks (for removing trapped air)	1 no

4.3.2 Materials and Consumables for Platform Construction (Borehole)

Item	Approx. Quantity
Washed Sand (without too much mud content)	2 cubic meters
Gravel (approximately Ø20 mm)	4 cubic meters
Cement (bags of 50 kg)	8 bags x 50 kg
Burned bricks (3" x 4.5" x 9")	100 nos
Wire netting for platforms (50 x 50 x Ø3 mm)	1.7 x 1.7 m
Reinforcement bars for dug-well covers (Ø6 - 8 mm)	15 m
Binding wire for connecting reinforcement bars	10 m
Hessian cloth for curing of platform	to cover platform
Pump stand (for stand with 3 legs)	(1 no)
Anchor assembly (for stand with bottom flange)	(1 no)
Wooden board (protection against contamination)	1 no (bolted on flange)

4.3.3 Materials and Consumables for Platform Construction (Dug-well)

Since most dug-wells differ in size, the quantity of material required for the construction of a platform including wellhead and well cover has to be calculated.

4.3.4 Materials and Consumables for Soak Pit Construction

Additional materials used for the construction of a soak pit:
sand, pebbles, stones of different sizes, bricks, bamboo matting, hessian cloth or jute-bags.

4.4 Preparation for Grouting the Platform for a Borehole

If the protruding well casing is not already closed with a top cap, cover it with a clean piece of a cloth or a plastic bag and secure it with a string. This cover should remain in place until the pump stand is finished and the handpump installation takes place.

Step by step manufacturing of the platform is explained in the following sequences:

4.4.1 Setting out

After the decision has been made, in which direction the handpump has to be placed, the first peg is placed 35 cm from the protruding casing pipe. This peg should take advantage of the natural slope of the area i.e. it should be sited downhill of the casing if at all possible.

This peg is the centre of the platform and from this position the **Centre lines (CL)** are set and marked with pegs. Clear the platform construction area of bush and surface irregularities.

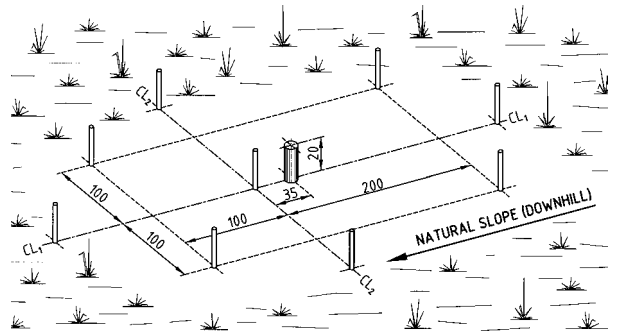

4.4.2 Marking Foundation

Make a loop at the end of a string and place it over the peg in the centre. Attach another peg at the required distance (75 cm) to the other end and mark the inner circle (radius 75). Afterwards, use the same system as above to mark the circle with radius 100. Mark all other measurements as given in the picture. For better marking, small pegs or short branches can be placed in 5 to 10 cm distances along the marked line.

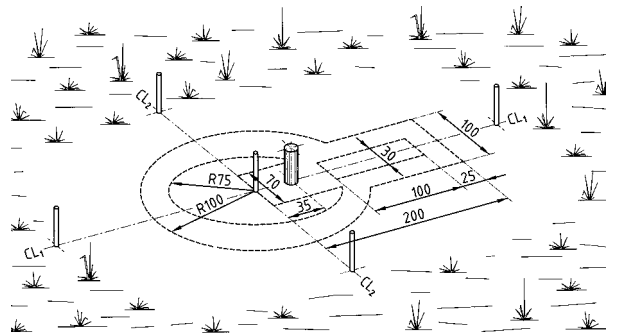

4.4.3 Digging Foundation Trenches

Dig the trench for the foundation carefully and make sure that the marked outline of the platform does not get damaged during digging. The foundation trench is finished as soon as the depth is a uniform 40 cm, which can be checked from any point of the prepared surface.

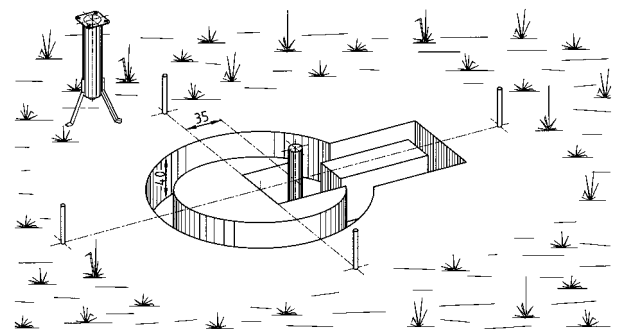

4.4.4 Placing the Pump stand

It is important that the pump stand, which is placed over the protruding casing pipe is at the correct height and is absolutely vertical.

The pump stand needs to be secured well with stones or wooden struts, so that it does not change its position during the grouting process.

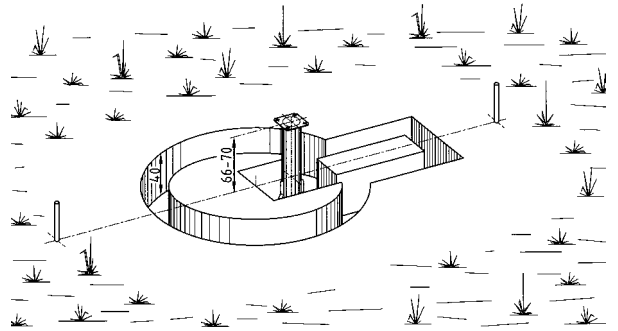

Remove the cover of the protruding casing pipe. Place the pump stand over the pipe and check the centricity of the casing inside the standpipe.

Make sure that the flange of the pump stand is pointing in the right direction.

Put stones underneath the legs of the pump stand, until the flange is at the required height of 66 to 70 cm from the platform base (or 106 to 110 cm from the floor of the excavations).

It is important to check that the flange of the pump stand is completely horizontal in all directions. Check this using a spirit level and adjust the pump as required. To secure this position, use stones or wooden struts.

4.4.5 Final Preparation prior to Grouting of Platform

Before starting with any concrete work, check whether all preparation work is completed, so that the different cement work (wet in wet system) is not interrupted too long. It is very important that enough raw materials have been collected to complete the following steps without interruption before any mixing of concrete should start.

- Cement, sand, gravel, bricks (and enough water),
- Reinforcement bars or netting,
- Shuttering material (or form work) for the platform ring and drainage channel,
- Steel bars for connecting platform and drainage channel (2 off)

Prepare enough concrete for filling the entire foundation space up to the ground level.

1 part of cement

2 parts of sand

4 parts of gravel



The mix should be 1:2:3.

This means:

- 1 volume of cement,
- 2 volumes of sand and
- 3 volumes of gravel.

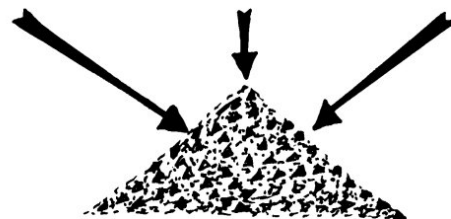

Mix the cement, sand and gravel thoroughly, before water is added.

mix thoroughly before adding water

For grouting sequences see following pages:

4.5 Grouting the Platform

4.5.1 Fill Foundation with Concrete.

Before the concrete is compacted, check again the flange for horizontality and adjust if necessary. Compact with a vibrator or by hand (use a tamper) to remove trapped air.

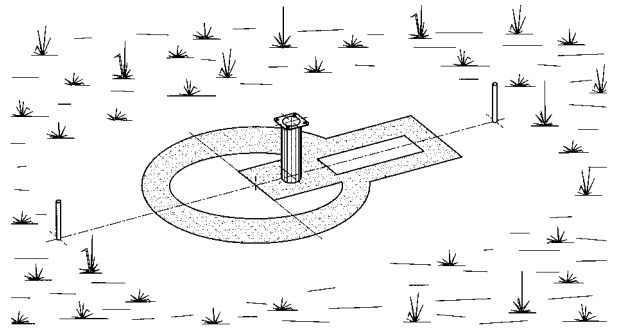

4.5.2 Reinforcement of Platform and Placing of Shuttering

Place (and bind together) suitable reinforcement bars on the platform area, or lift preformed netting over the pump stand. Support the reinforcement with small stones or with the help of cement cubes in order to lift it to the required height. The position of the reinforcement should be between 2 to 3 centimetres below the finished cement surface. Place the shuttering (formwork) and support it with pegs or heavy stones.

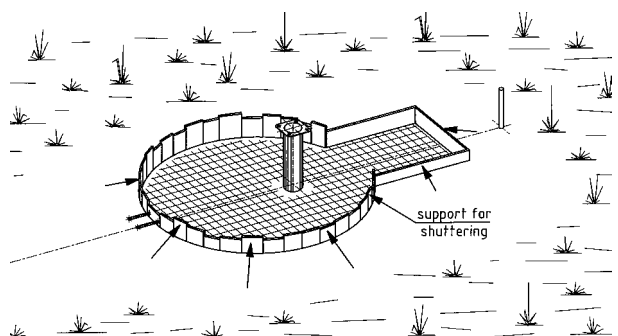

4.5.3 Casting of Well Platform and Operation Platform

Prepare enough concrete for casting the platform. Fill the platform with a concrete layer of 12 cm and compact by tamping.

After a curing time of approximately 1 to 2 hours, the shuttering can be removed carefully.

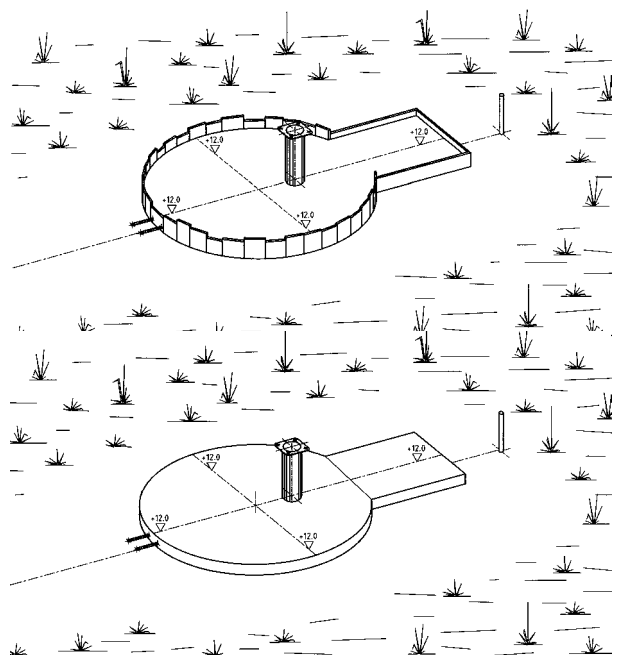

Prepare enough mortar for the final layer with slope and bricks for constructing the ring of the platform.

Now the final layer for the slope can be applied. Make sure that the slopes are in the right direction.

After a short while of applying the final layer (15 to 30 minutes), the bricks for the ring of the platform can be placed.

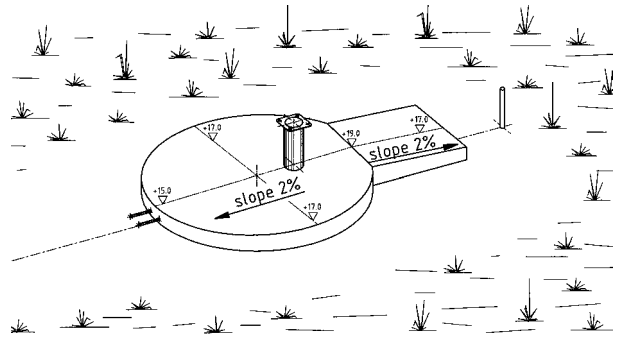

4.5.4 Casting of the Drainage Channel

During the curing time of the well platform, all work for casting the drainage channel can be started. Proceed as follows:

Dig the required trench for the drainage channel and make sure that the 2% gradient on the downward slope of the platform continues right to the end of the channel.

Place and secure the formwork of the 6m long drainage channel. If required, place the reinforcement bars or netting. Prepare sufficient concrete and cast a layer of 12 cm.

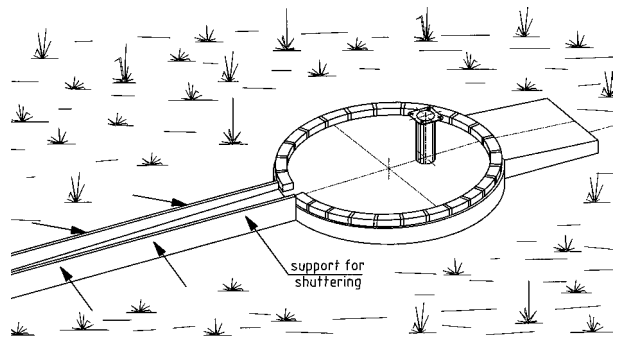

After a curing time of approx. 1 to 2 hours, the shuttering can be removed carefully. Prepare mortar for final layer and enough bricks for the two rims on drainage channel. The bricks can be placed 15 to 30 minutes after the final layer has been applied.

After the bricks are in position, all final work (like finishing and smoothing all surfaces of the platform and the drainage channel) can start. Make sure that all top corners of the platform ring and the rims of the drainage channel are made with chamfers and a radius is applied between the platform and the ring.

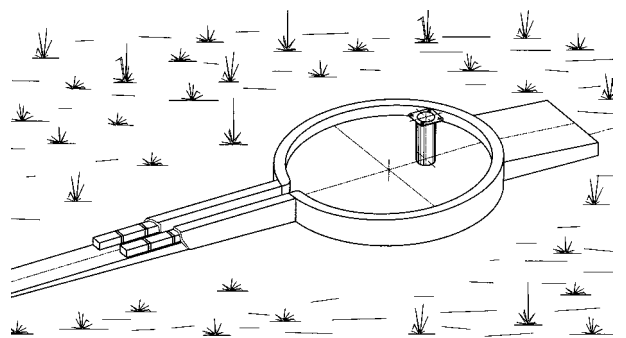

4.5.5 Grouting of Platform for Pump stand with Bottom Flange

When grouting of a platform for the Pump stand with Bottom Flange, the normal procedures as described before can be followed.

The only difference to the platform for the pump stand with legs is that the Bottom Flange is placed in top of the slab and only the Anchor assembly needs to be grouted.

Therefore the foundations at the casing pipe can be made more shallow. It is also advisable to raise the surface of the flange by approximately 3 cm, to make it exactly level. (see picture).

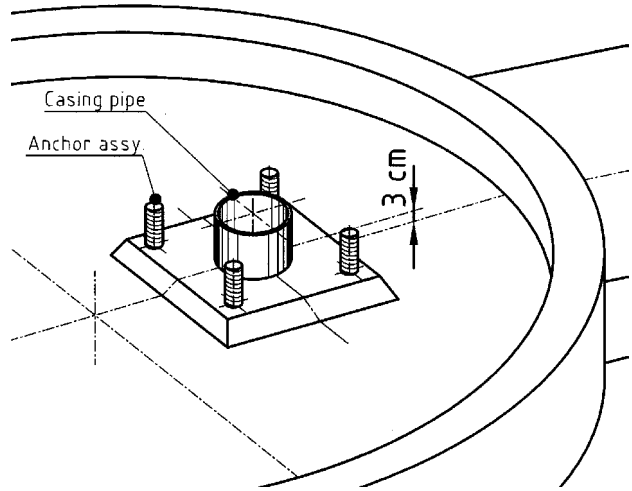

When placing the anchor assembly for grouting, make sure that the anchor bolts are protruding the top face of the raised surface by 4 cm.

4.5.6 Grouting of Covers for Dugwells

Dugwells need to be closed by a strong cover, on which the handpump can be installed.

Form a ring of bricks according to the well diameter and cover the whole surface with with plastic sheets.

Place the anchor assembly, a wooden plug (forming the “Manhole”), two handles and the reinforcement bars, and fix the whole assembly with binding wire prior to grouting.

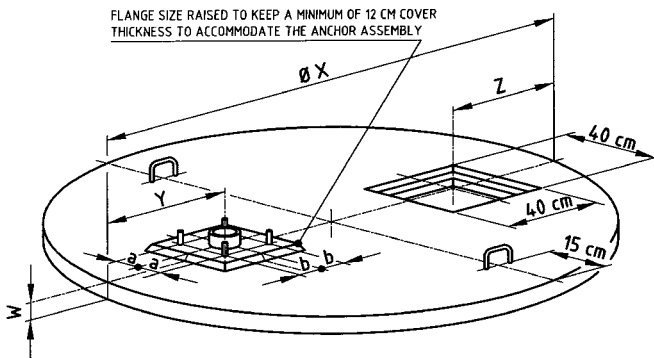

Grouting procedure and curing time etc. is comparable to the construction steps of the platforms.

For exact positioning of the anchor assembly and the plug for the “Manhole”, see sketch at the left side.

* SEE DRAWING OF PUMP FLANGE

Single Well Covers

Well outside Ø X	Dimension Y	Dimension Z	Cover thickness W	Dimension a *	Dimension b *
1.2 to 1.5 m	50 cm	30 cm	Ø10 cm	according to pump configuration	
1.5 to 1.8 m	50 cm	35 cm	Ø10 cm	according to pump configuration	

For dug well covers with an outside Ø over 1.8 m, covers need to be split and supported by beams

For more details see also “3.5.6 Grouting of Platform for Pump stand with Bottom flange” on page 21.

4.6 Curing of Platform

Following the final touch of the platform, protection is required from being destroyed: As soon as all final work is completed, all cement work needs a curing time of at least one week.

During the curing period, the platform needs to be watered regularly, so that it never gets dry.

Partitions made of clay or other material blocks the water from being drained after watering. Before leaving the water point, cover platform and drainage channel with thorn bush, so that it is well protected from being destroyed by passing people or by animals attracted by the water.

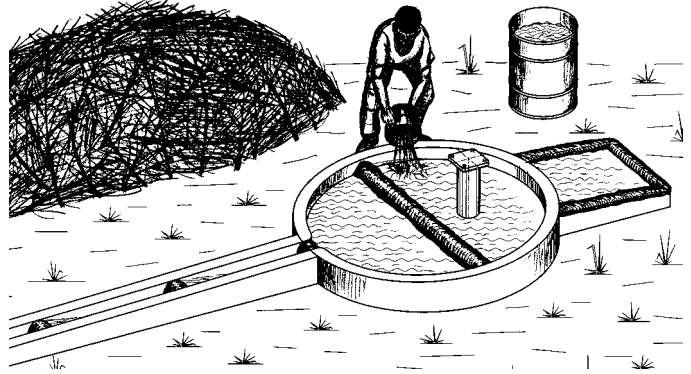

4.7 Hard Core Layer and Fencing of Platform

4.7.1 Hard Core Layer around the Platform

A hard core layer should be placed around the platform. This acts as a protection of the concrete platform and prevents spill water to create a swampy muddy area. Proceed as follows:

Mark the outside line of the hard core layer and dig as much as required, so that the brick or stone layer is level with the ground surface when finished.

Bricks or stones are placed on mortar or sand and the joints are filled with mortar.

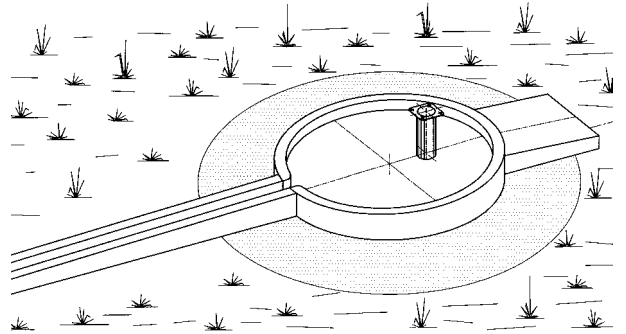

4.7.2 Fencing of Platform

The entrance of the fence should be able to be closed or be made as narrow as possible, so that no animal is able to enter the well point (see also 3.1.5).

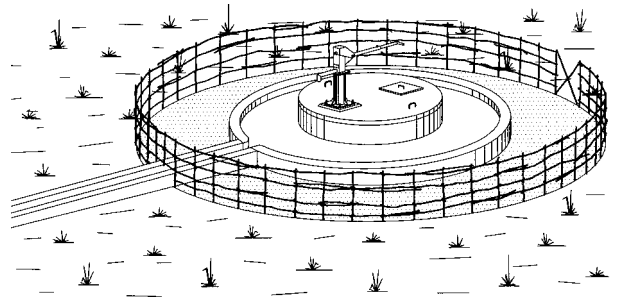

4.8 Soak pit

Construct a soak pit if natural drain is not available. In the picture you will see a typical construction of a soak pit.

Fill the excavated hole with stones, broken bricks, gravel and cover with sand.

To prevent that sand is washed away, fix a mud pot (with holes at the bottom) at the end of the drainage channel, so that the spill water can drain slowly.

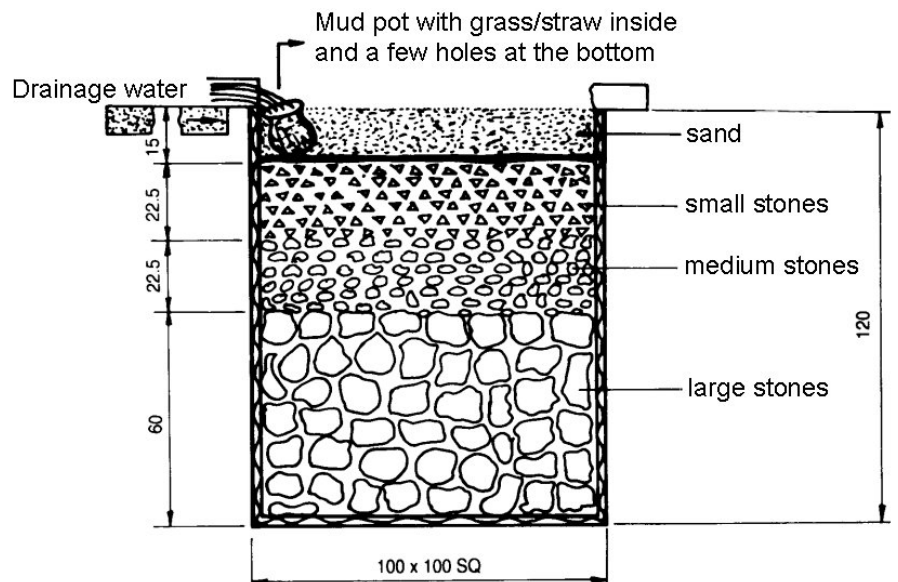

4.9 Disinfecting the Well

As soon as the curing time is over and the platform is ready for installation of the handpump, the well needs to be disinfected with chlorine.

Many of the diseases that are common in the communal lands are carried by water, especially from unprotected wells, water holes, rivers and dams. Dysentery, diarrhoea and typhoid can arise as a result of drinking water that is infected. The disease carrying organisms found in the water can be effectively killed by disinfecting the water with chlorine.

Therefore it is recommended to disinfect the well shortly before the installation of the handpump takes place. Proceed as follows:

Mix 300 grams of bleaching powder thoroughly in 15 litres of water in a bucket and pour the solution into the borehole.

The required dosage of bleaching powder for dug-wells is depending of the amount of water stored in the well. It is recommended to use between 150 to 200 grams of bleaching powder per cubic meter water for safe disinfection.

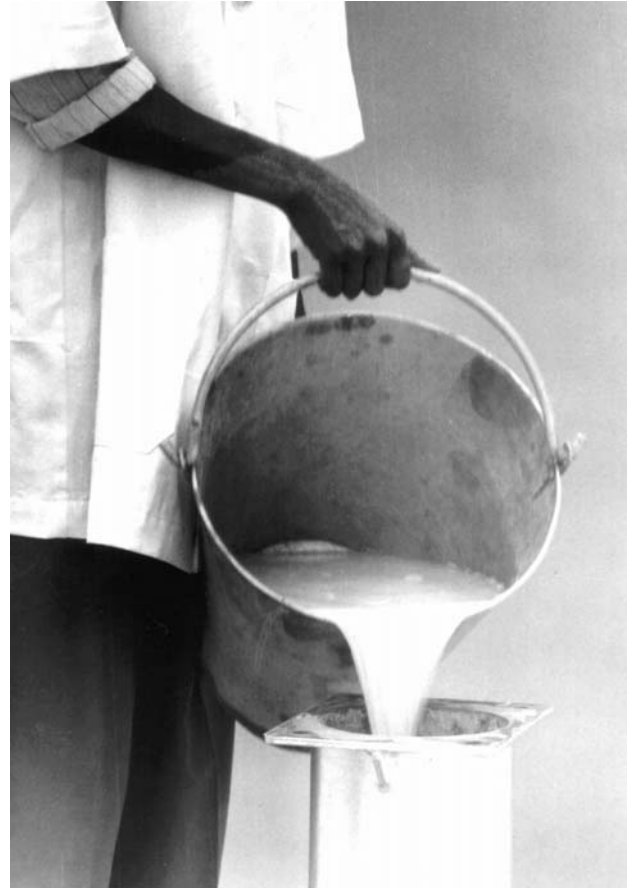

5.0 Preparation for Handpump Installation

5.1 Decision on correct Cylinder Setting Depth

5.1.1 Static Water Level (SWL)

One of the important factors for the cylinder setting is the surface of the water in a well, which is called “Static Water Level” (SWL). The SWL can vary due to seasonal conditions (dry or wet seasons) and therefore should be checked and recorded over a period of several years. Such records would be important for the decision at what depth the cylinder should be placed. Checking the depth of the SWL in a dug-well can be done through the manhole or a special hole provided in the well cover, the same procedure is more difficult if an Afridev is installed in a borehole. The pump head cover, the handle and the pumprods need to be dismantled, before checking of the SWL can start.

5.1.2 Dynamic Water Level (DWL)

Apart from seasonal fluctuations, there are also fluctuations in the well itself because of pumping water from the well. In order to check the drop in the water level (draw down) and to find the DWL, test pumping on a new borehole should be done by the drilling crew.

For handpumps, the test pump should be set for 1000 litres per hour (maximum) in order to see where the DWL is reaching. These tests should be continued for approximately hours, in order to ensure the correct DWL. This figure is another important factor for deciding on the best setting depth of the handpump cylinder.

(On marginal holes, pumping rate might be reduced to 800 litres/hour.)

5.1.3 Other important factors

- Any pump intake in a borehole must be set above the well screen in fully screened well or above any rock fissures providing water in an unlined well. A pump intake above the well screen or rock fissures is minimizing the turbulent flow of water and therefore reduces the pumping of fines and silts.
- Pumping water with a too high content of fines or silt is wearing the surface of the pump cylinder and the plunger seals in an unacceptable rate.
- If a pump cylinder is placed too close to the bottom of a borehole, silt and sand could build-up and trap the pump in the hole.

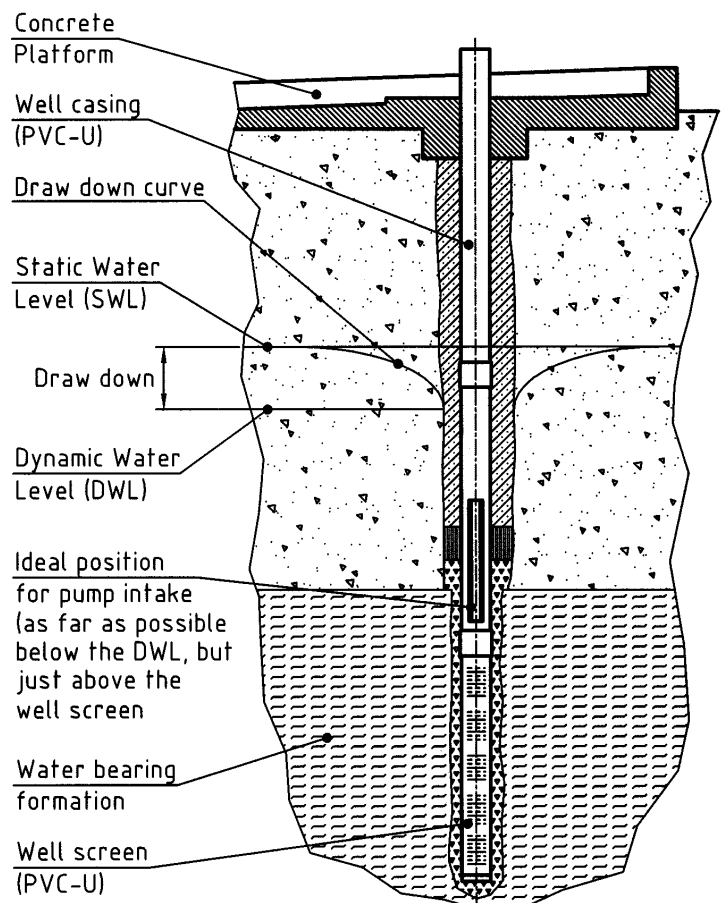

5.1.4 Cylinder setting in Boreholes

- Check the depth of the DWL and the depth where the well screen starts (information must be available from the drilling crew). The start of the well screen should be considerably lower than the DWL. If there were a large difference, it would be ideal to place the cylinder approximately 1 meter above the well screen.
- Check the SWL regularly, especially during the dry season, in order to avoid that the newly installed pump is running dry. Should the cylinder setting depth be critical during the dry season, add one length of riser pipe and one pumprod.

5.1.5 Cylinder setting in Dug-wells

- The cylinder setting for dug-wells is not so critical, because the SWL can be checked regularly through the manhole. It is advised to place the cylinder as such, that the suction pipe is at least 0.5 meter above the well ground, to minimise pumping of silt and sand.
- Should the SWL drop in the dry season to such a level that the pump is running dry, increase the depth of the dug-well by some meters.
- Adjust the rising main by adding additional riser pipes and pumprods.

5.2 Material and Tools required for Installation of “Down Hole Components”

5.2.1 Tools and Equipment

- | | | |
|----|------------------------------|--|
| a) | measuring tape | marking exact length and square cutting line, |
| b) | pencil / permanent marker | marking prior to cutting, |
| c) | hacksaw | easy cutting of PVC-U pipes, |
| d) | pocket knife | deburring of inside edges (inside chamfering), |
| e) | rasp or coarse file | chamfering the inside and outside edges, |
| f) | sand paper 60 – 80 grit | roughening of jointing surfaces, |
| g) | brush, flat 50 x 4 mm | for outside application of solvent cement, |
| h) | brush, flat 25 x 3 mm | for inside application of solvent cement, |
| i) | white absorbent paper | cleaning paper (or toilet paper), |
| j) | small bowl (Bakelite or tin) | for easy application of solvent cement, |

5.2.2 Material

- | | | |
|----|----------------|-----------------------------|
| a) | Cleaning fluid | Carbon tetra chloride base, |
| b) | Solvent cement | Tetrahydrofurane base, |

5.3 Preparation of “Down Hole Components”

- 5.3.1 Prepare a suitable working place not too far from the well point (place two logs for resting the pipes in a clean place above the ground), preferably in a shady place.
- 5.3.2 Calculate all pipes needed for the required installation length and add a cylinder, a suction pipe, the needed number of rising main centralisers and the top sleeve.
- 5.3.3 Slide all centralisers over the pipes until they rest at the beginning of the bell-ends. One centraliser is placed at the end of the cylinder (use a little water for easy sliding).
- 5.3.4 Place all pipes and the cylinder with suction pipe neatly next to each other on top of the two logs and clean all parts from dirt and dust.
- 5.3.5 The rope for supporting the rising main during the jointing process needs to be stretched out on the ground and straightened (removing all kinks). Then the two ends should be brought together to find the midpoint of the rope, where a knot needs to be made. Place the rope neatly on the ground near the well platform and make sure that it is in a clean place, to avoid contamination of the well during installation.

- 5.3.6 Mark each pipe end with a pencil or permanent marker at 115 mm (the position where the bell-end will rest after jointing).

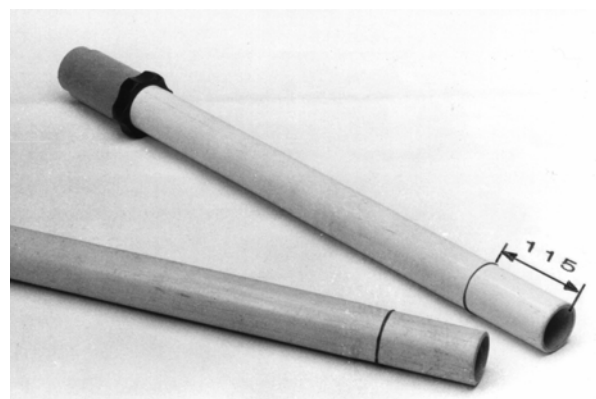

5.3.7 If one of the pipes needs to be shortened, mark the exact position (a line around the whole pipe) and cut along the line with the hacksaw, remove the burrs with a knife.

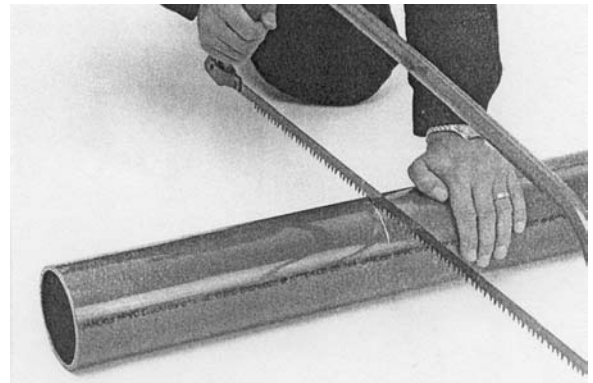
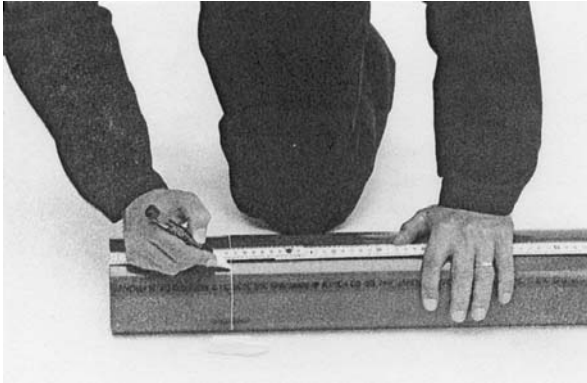

5.3.8 Check all pipe ends for exact chamfer sizes, make chamfers if necessary with the rasp or coarse file (Note: both inside and outside chamfers are required, see sketch).

chamfered 5 x 15°
(inside and outside)
all sharp edges rounded

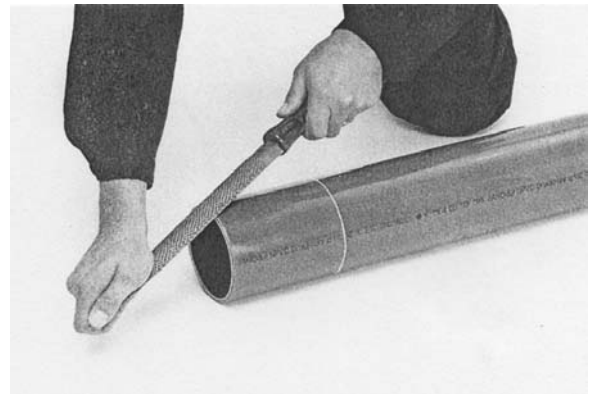
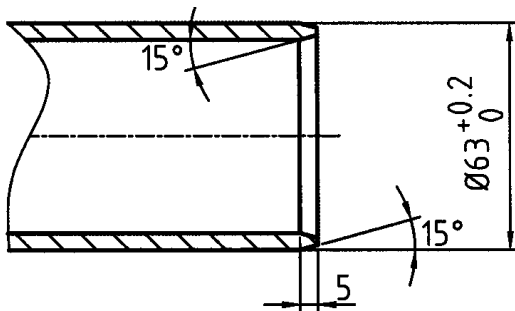

5.3.9 All pipe ends (outside) up to the marked line and also all bell-ends (inside) need to be slightly roughened with sand paper until the surface appears matt.

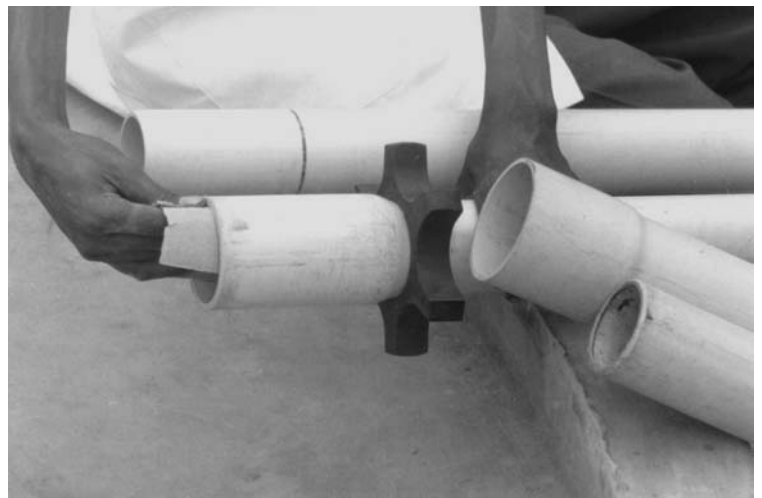

5.3.10 Then the roughened surfaces need to be cleaned properly with the cleaning fluid to ensure that they are free from any oil or grease (use a new paper with cleaning fluid as soon as any dirt is visible on the white paper).

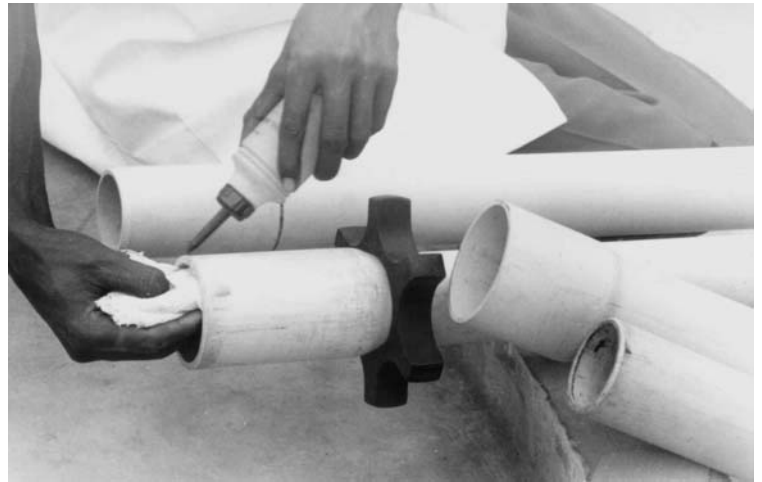

5.3.11 Let the cleaned surfaces dry for approximately 5 minutes and make sure that nobody touches the prepared surfaces with their hands.

5.3.12 Pass one end of the rope through the 10 mm hole of the suction pipe until the rope stops because of the knot. A second knot needs to be made at the other side of the suction pipe, so that the rope is fixed and cannot be pulled out to either side.

5.3.13 Clean the apron of the pump point, and prepare all the tools that are needed for the application of the solvent cement and the jointing procedure.

5.3.14 Fix two bolts in two opposite holes of the pump stand flange so that it is possible to tie the rope to them (see picture of 5.1.4).

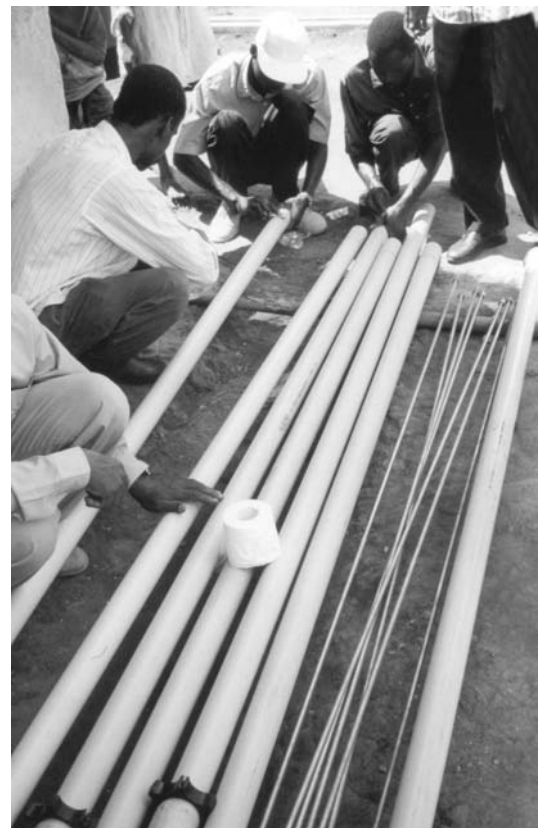

- Note:**
- a) Well chamfered and rounded pipe ends prevent the layer of cement from being stripped off, as the pipe is inserted into the bell-end.
 - b) The mark of the jointing length (115 mm) on the pipe ends makes it possible to check afterwards whether the pipe has been inserted to the full extent of the bell-end.
 - a) The bell-ends of the standard pipes are slightly tapered and designed as such that the pipe cannot be inserted dry into the bell-end. This will only become possible once the cement has been applied.

Do no attempt to make a joint that does not achieve an interference fit when dry. This can be checked by inserting the spigot into the bell-end before cement is applied – if the pipe end (spigot) slides fully into the bell-end, it will not be possible to cement this joint satisfactorily, so this pipe should not be used here.

5.4 Important Information for Jointing PVC-U Pipes

5.4.1 Solvent Cement Jointing:

Solvent cement jointing (welding process) of PVC-U pipes offers a simple and quick means of construction high integrity leak-free joints. Correctly made joints are stronger than the pipe itself. The solvent cement operates by chemically softening the outside of the pipe end (spigot) and the inside of the bell-end (socket). Joint integrity is greatly reduced if these surfaces are not absolutely clean and properly prepared.

This fact calls for adequate technical knowledge, clean working conditions and exact preparation procedures. The jointing instructions (see **5.1 Installation of “Down Hole Components”**) are intended to assist all those who are using this technique for the installation of PVC-U rising mains for handpumps.

5.4.2 Clean Working Condition:

As mentioned before, a clean working environment is necessary for receiving strong and leak-free pipe joint results. Without too much of a hassle, the working condition around the well point can be organised as such that clean working is possible. This includes:

- a) placing PVC-U pipes on logs for preparing/cleaning of joints (in a shady place),
- b) Placing pumprods on logs near the well (beware of dirt/sand entering threads),
- c) Cleaning material (Fluid & Toilet paper) and jointing material (solvent cement, bowl & brushes) in a shady, clean and dry place (see also “Tips for working with Solvent Cement”, page 36).

5.4.3 Organised Working:

Since it is of great importance that each jointing process has to be completed within a short period (recommended is 1 minute), the tasks of the installing personnel have to be organised. In order to have sufficient time, it is advisable that the application of solvent cement is made by two persons, one for the pipe ends and one for the bell ends.

3 people are required for pushing the pipes together; one for pushing the bell end over the pipe end and two people for gripping the pipe end, so that stretching of the supporting rope can be reduced.

One person is responsible for the time; he gives the command for starting of solvent cement application, for pushing the pipes together, for keeping the required curing time and he also informs the crew when lowering of the joined pipes can start.

5.4.4 Excessive Applications of Solvent Cement:

Do not use excessive solvent cement when preparing for a new joint. A too thick layer of solvent cement will be scraped from the surface when the pipes are pushed together and will lead to a deposit inside the bell-ends. Large deposits inside the bell ends must be avoided as these can weaken the wall of the rising main pipe or might build up as much that the inside diameter of the pipe will be reduced and the plunger will not be able to pass through.

5.4.5 Curing Time for new joints, before next jointing can start:

- a) **Every new pipe joint during installation:**
For any new pipe joint, a curing time of at least 5 minutes is required, before the assembled pipes can be lowered by the ropes and a next joint can be started.
- b) **Last joint at the end of the rising main pipe (Top sleeve):**
The curing time for the top sleeve should be at least 20 minutes, before the completed rising main is lifted for tightening the rope ends to the cone plate (see also 5.1.14).
- c) **Complete rising main before pump is allowed to be operated:**
It is essential that the whole rising main be allowed to cure for at least 12 hours until the maximum load applied can be taken by the joints (operation pressure, weight of water column and stretching of the pipe due to the oscillating movement during operation of the pump).

5.5 Preparation of “Above Ground Components”

5.5.1 Assemble the “bearing bush sets” by pressing the bushes together by hand (4 sets per pump).

5.5.2 Slip on one centraliser on each pumprod.

5.5.3 Keep all prepared rods on a clean place, preferably laid on a stand made of two logs close to the installation spot and make sure that all threads are cleaned from sand or mud.



5.5.4 Place all remaining pump components like pump cover and handle parts close to the installation spot and keep the small components like bearing bushes, fulcrum- / hanger pin and all nuts and bolts in the pump head cover.

6.0 Handpump Installation Sequences

6.1 Installation of “Down Hole Components”

Note: The joint should be completed in less than 1 minute from the time when the application of cement begins.

6.1.1 Pour an adequate amount of solvent cement into the small bowl and apply a layer of cement to interior surface of the bell-end of the suction pipe and a layer to the cylinder (or spigot) end.

6.1.2 Place the end of the suction pipe on the apron and insert the cylinder in “one go” into the bell-end of the suction pipe.

6.1.3 Remove any surplus solvent immediately with absorbent paper.

6.1.4 After a curing time of at least 5 minutes, insert the suction pipe with cylinder into the pump stand and lower it so that the cylinder top is protruding by about 0.5 m. Then tighten the two ropes on the two prepared bolts on the pump stand flange.

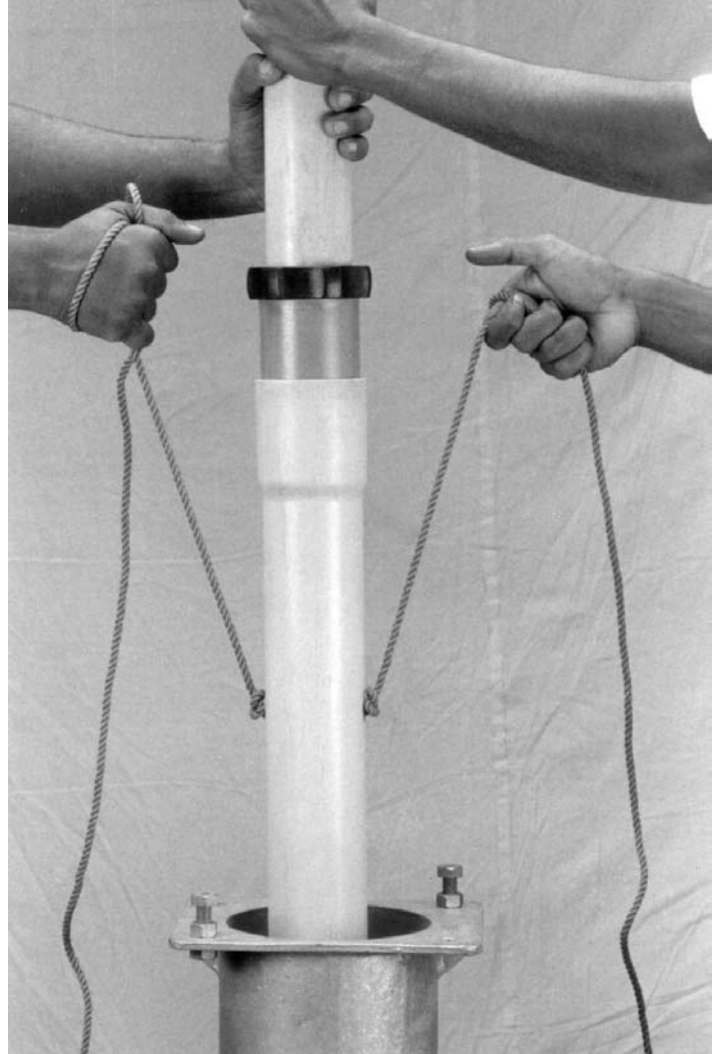

6.1.5 Apply solvent cement to the inside of the bell-end with the smaller brush and at the same time the application to the pipe end of the protruding pipe should be made with the bigger brush. The brush strokes should always be in an axial direction. Ensure that both jointing surfaces are completely covered with a smooth and even layer of cement. (Application time should never exceed 30 seconds for each surface.)

- 6.1.6 Bring the riser pipe into position and push the bell-end **immediately** “in one go” over the protruding pipe until its end position.

Don't twist the newly inserted pipes anymore, as soon as they are pushed together.

During this strong pushing procedure, the cylinder or the lower pipes needs to be supported by hand (requiring at least 2 workers), so that the whole force of the “Push” is not taken by the fixed rope alone.

- 6.1.7 Remove any surplus of solvent cement immediately with absorbent paper.

- 6.1.8 Allow the joint to set at least for minutes before loosening the ropes for lowering the pipe into the position for the next joint.

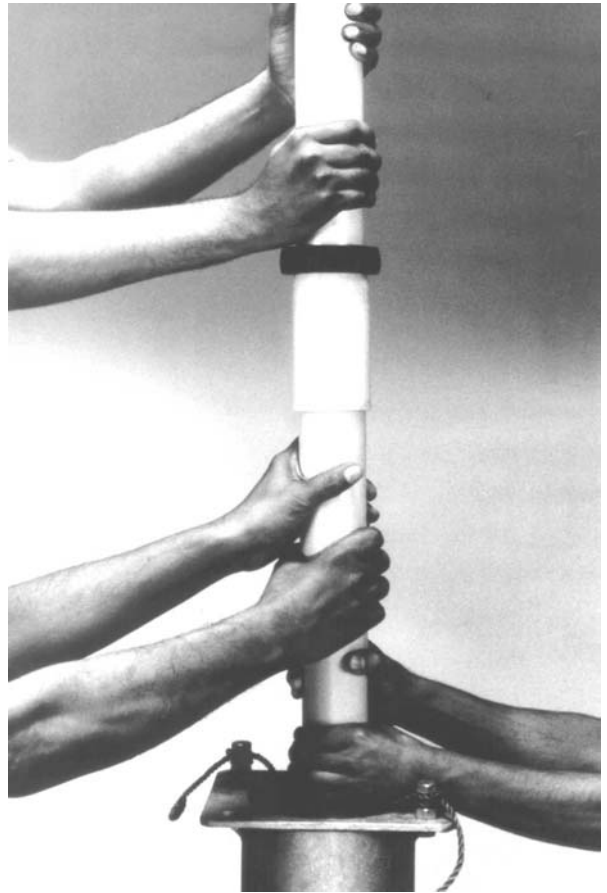

- 6.1.9 When lowering the pipe, place the rope into two opposite grooves of the centralisers and never support or hold the pipe by hand (support only by the two rope ends) since the weight of the pipe should not be taken by the newly made joints.

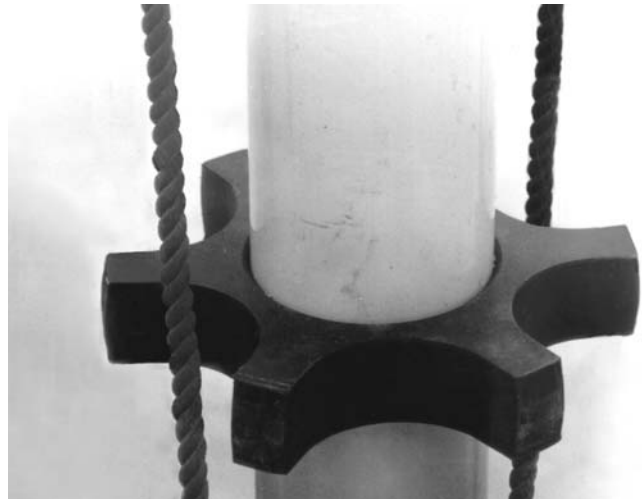

6.1.10 As soon as the protruding pipe is in the required position for the next joint, secure it by fixing the rope to the bolts on the pump stand flange.

This procedure needs to be repeated until the last pipe is connected.

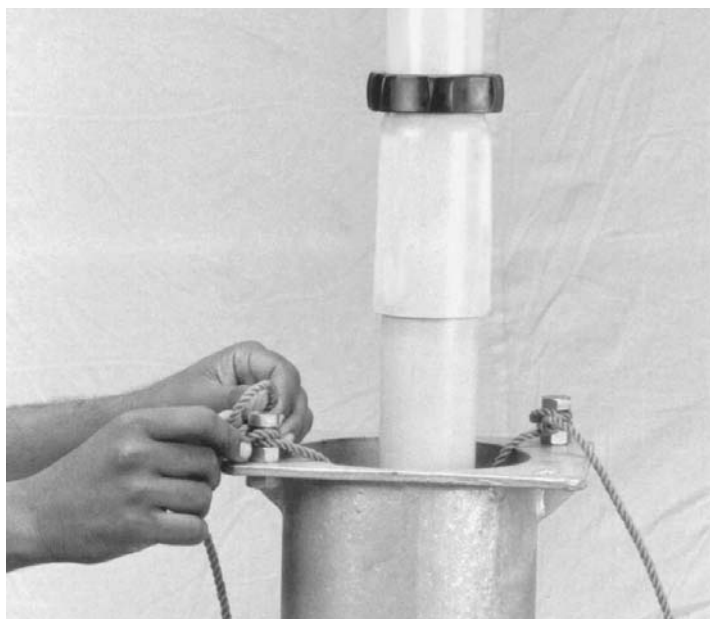

6.1.11 As soon as the last pipe is lowered, the steel cone is inserted and laid to the top flange of the pump stand. Then the rubber cone has to be slid over the pipe, so that the pipe end is protruding by approximately 100 mm.



6.1.12 Clean the protruding pipe end again with cleaning fluid and as soon as it is dry, apply solvent cement to the pipe (80 mm depth) and also to the inside of the top sleeve.

6.1.13 Allow the jointed top sleeve to set for at least 20 minutes, before the rubber cone and the steel cone are adjusted.

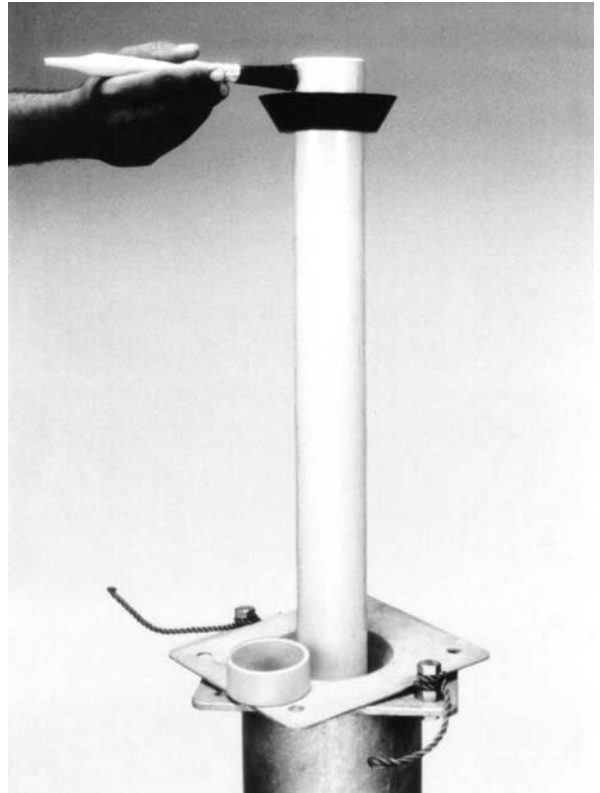

6.1.14 After the setting time, one or two persons should lift the complete rising main assembly by the steel cone, while a third person starts to connect both rope ends to the eyes of the steel cone with two or three securing knots.

6.1.15 When cutting the rope ends, leave at least 2 m excess length (this makes it easy for connecting another rope for easy removal, in case the rising main assembly needs to be pulled out for repair).

6.1.16 Insert the rope ends into the pipe of the pump stand or the casing pipe, lower the whole rising main assembly onto the pump stand flange and remove the bolts from the flange.

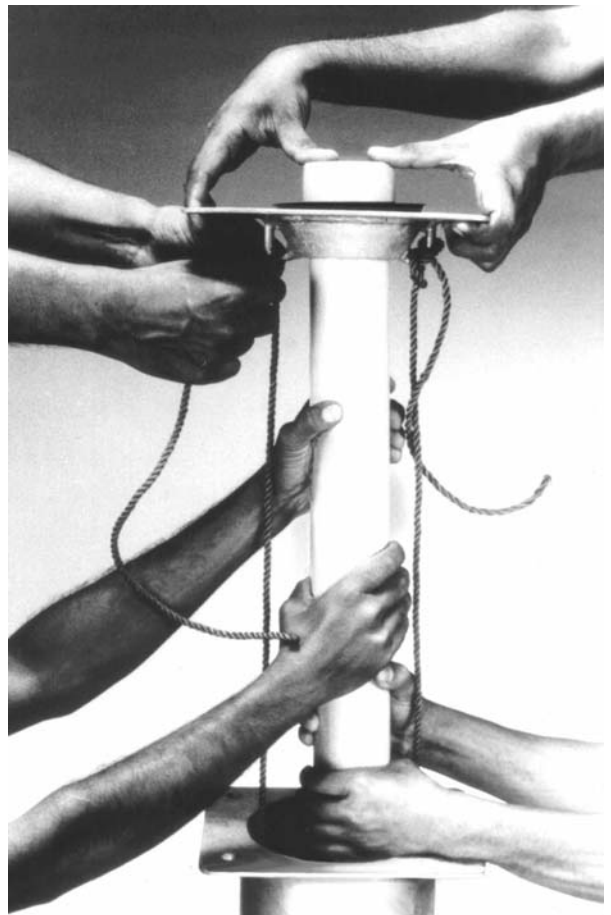

- 6.1.17 Move the steel cone so that all four holes of the cone plate and the pump stand flange are matching.

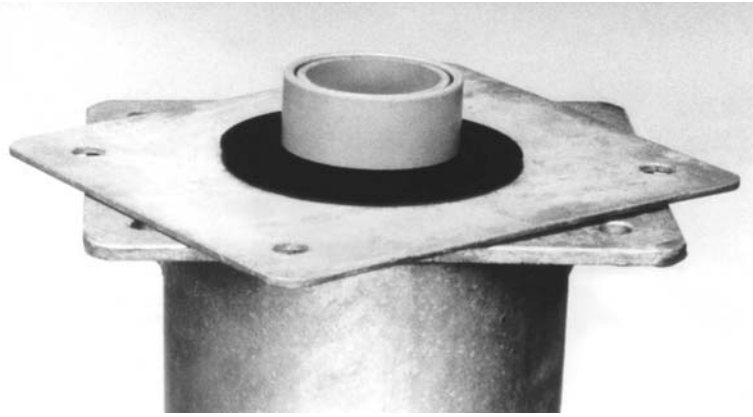

- 6.1.18 Cover the hole of the newly installed rising main pipe to prevent playing children from dropping dirt or stones into the well and let the joints cure for at least 12 hours.

Tips for working with Solvent Cement:

- a) Remove any skin, which may have formed on the cement in the tin.
- b) Stir the solvent cement thoroughly.
- c) Solvent cement should have the correct consistency. It should run smoothly from the bottle into the small bowl. Cement that no longer runs smoothly is unusable. Therefore never expose solvent cement to the sunlight and store it in a dry and cool place. (The same applies also to the cleaning fluid.)
- d) Pour only the approximate amount of solvent cement into the small bowl that is used for the next joint and close the lid of the tin or the bottle immediately after pouring (to prevent the solvent evaporating).
- e) When applying solvent cement to the inside of the bell-end hold the pipe horizontally and use the smaller brush. Work the cement in well with brush strokes in the axial direction until it forms an even layer.
- f) Do not use excessive solvent cement and do not dilute or add anything to the solvent cement. Excessive deposits inside the bell-ends must be avoided as these can weaken the wall of the pipe.
- g) Use a shelter to keep jointing surfaces dry in wet weather.
- h) Clean the brushes and the bowl with dry absorbent paper after use. Brushes must be dry and flexible before being re-used.

6.2 Installation of “Above Ground Components”

6.2.1 Install pump head on stand assembly and tighten bolts fully.
Now the pump is ready for the installation of the plunger with the pumprods.

6.2.2 Attach plunger rod with the plunger and check that the bobbin and the cup seal (or U-seal) are in the correct position.

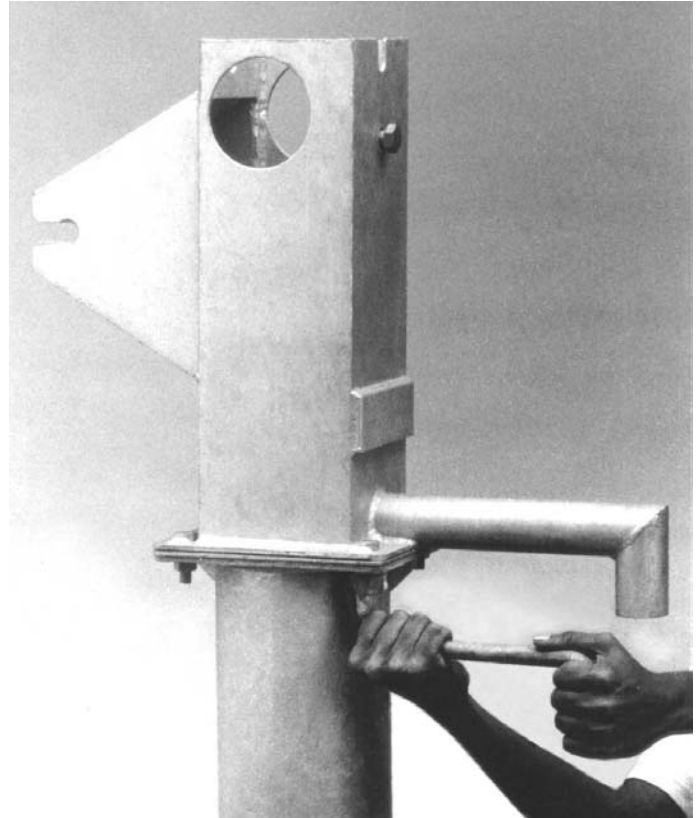

6.2.3 Threaded Pumprods
Connect first pumprod to the plunger rod and insert it into the rising main pipe.
Lower the pumprod assembly and place the **Resting tool** on the Pump head, so that the hexagonal connector is resting in the keyway of the limiters (see picture beside).

6.2.4 Lift the pumprod assembly slightly to release the resting tool, so that the newly fastened connection can be lowered.
As soon as the connection has entered the pump head, the resting tool can be placed again for preparing the next connection.

6.2.5 Connect all following pumprods and make sure that all connections are tightened securely.

6.2.6 After the last rod (Top rod) has been fastened, lower the completed pumprod assembly until the plunger is sitting on top of the footvalve.

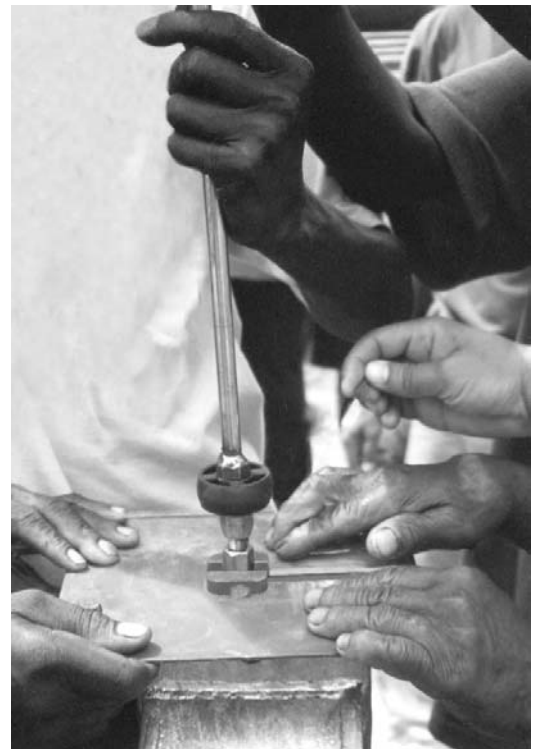

6.2.7 Pumprods with Hooks & Eyes

Connections are made by inserting the hooks horizontally into the eyes. Turn the horizontal rod upwards, so that the connection is tight and the rods are exactly in line.

6.2.8 Make sure that the free-hanging pumprod assembly is gripped securely by 2 or 3 people, so that it does not fall into the rising main assembly during this installation procedure.

6.2.9 Connect all pumprods as described until the plunger is sitting on top of the footvalve.

6.2.10 FRP Pumprods

The total weight of FRP Pumprods is about 1/3 of the conventional steel rods and in addition, they are also flexible.

Therefore it is easy to connect them outside of the borehole and lower it as a completed assembly.

6.2.11 To determine at what point the top rod needs to be cut, so that the pumprod assembly has the required length, proceed as follows:

- a) Let the pumprod assembly rest fully, so that the plunger is sitting on top of the footvalve.
- b) Insert one hand into the pump head and grab the protruding pumprod at the top end of the rising main pipe and use the thumb for keeping the exact measurement.
- c) Don't lose the grip of the pump rod, when with the help of two or three other people, the complete pumprod assembly is lifted by approximately one meter.

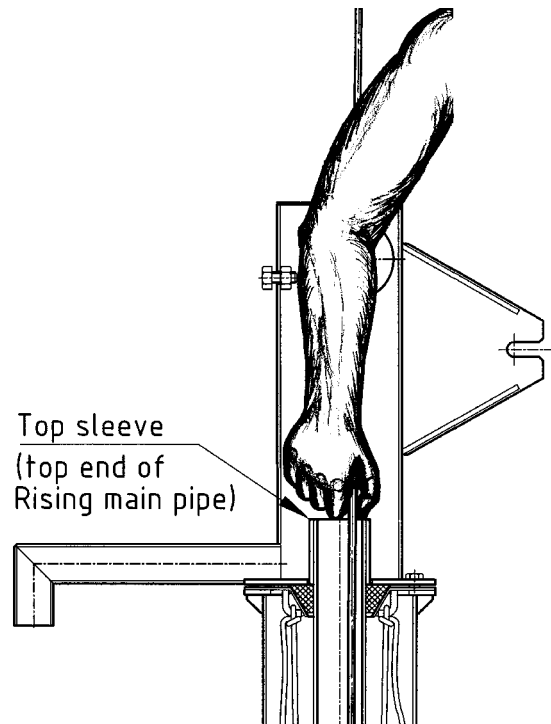
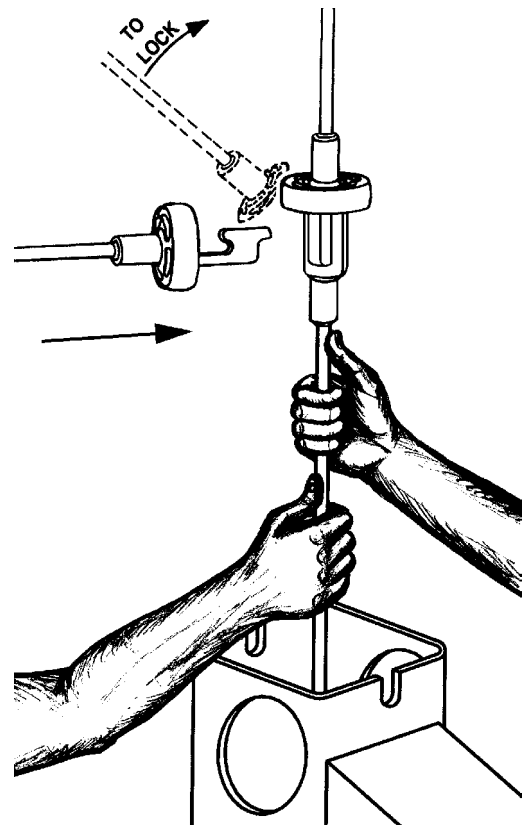

6.2.12 As soon as the hand is outside the pump head, mark the exact position of the thumb with a permanent marker.

6.2.13 After marking, lift the pumprod assembly as far as to the next connection and disconnect the top rod.

6.2.14 Cut the top rod at the mark and connect it again with the pumprod assembly.

6.2.15 Slip on flapper on the pumprod and fix the rodhanger assembly. Make sure that the rod is inserted to the full extent and that the hexagonal bolt is tightened securely.

6.2.16 Insert the spanner handle into the bush on top of the rodhanger and lower the complete pumprod assembly, so that the spanner handle is resting in the two slots provided in the pump head.

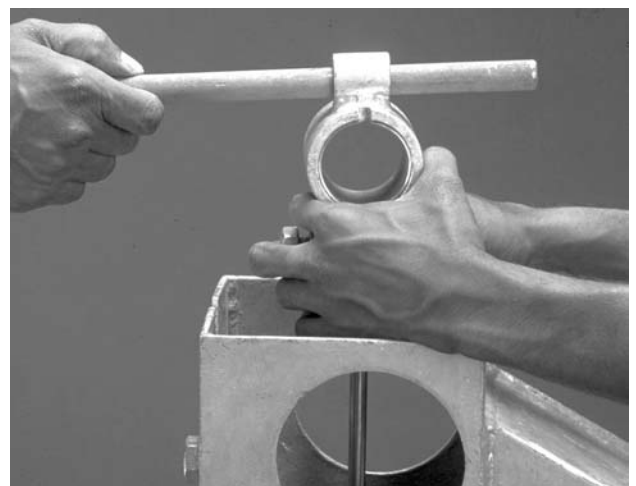
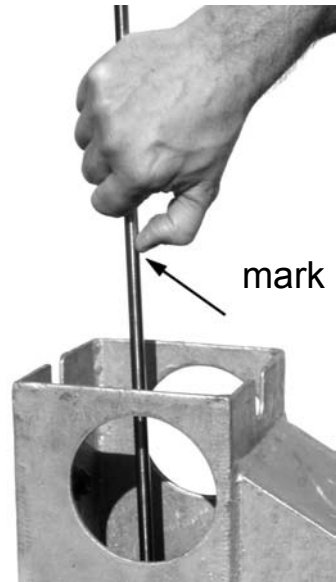

6.2.17 Prior to connecting the handle front assembly, assemble one bearing set with the fulcrum pin and insert it into the fulcrum housing of the handle front. From the other side attach the second bearing set and make sure that lugs are located in the slots of the fulcrum housing.

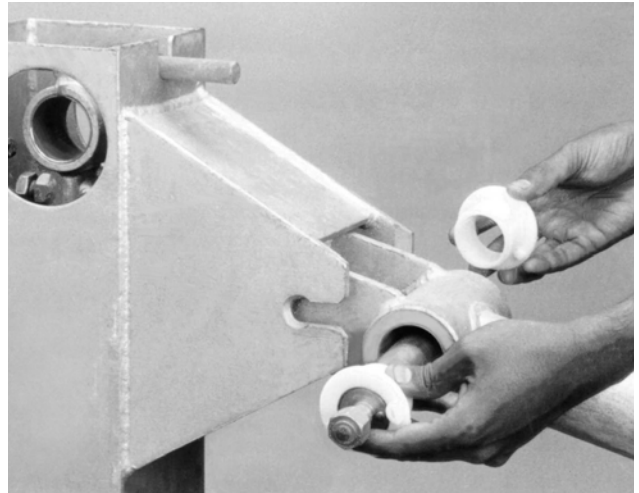

6.2.18 Adjust the lock pins of the fulcrum assembly and the two lugs of the bearing bush inner to the correct position (see sketch).

Then, the handle front can be inserted carefully into the slots of the fulcrum bracket.

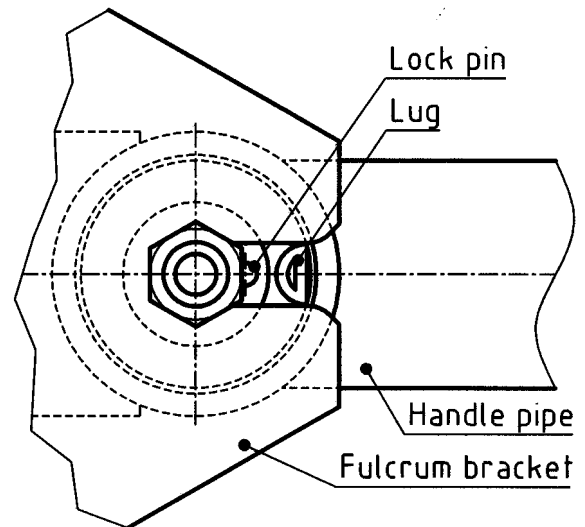

6.2.19 Insert the handle front fully and fasten the special nuts of the fulcrum pin by hand.

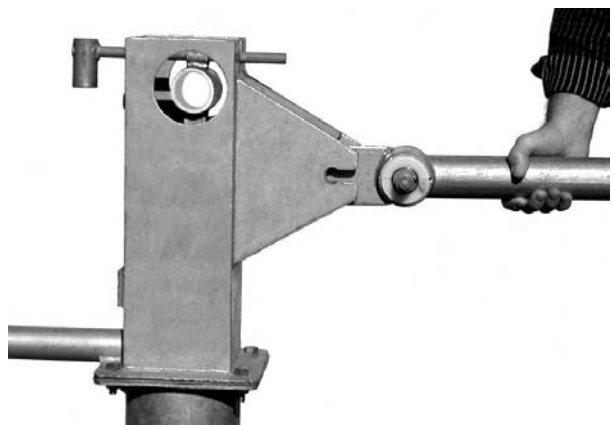

6.2.20 Prior to the next step, make sure that the handle is held securely in a horizontal position, in order to avoid pinching of fingers of the person who is assembling the rod housing.

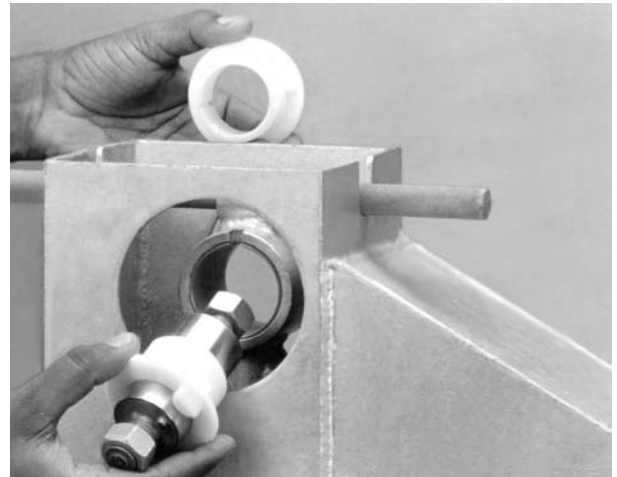

6.2.21 Assemble one bearing set with the rodhanger pin and insert it into the rodhanger assembly. From the other side attach the second bearing set and make sure that lugs are located in the slots of the hanger bush.

6.2.22 Adjust the lock pins of the rodhanger assembly and the two lugs of the bearing bush inner to the correct position (see sketch), before the handle front can be lowered carefully.

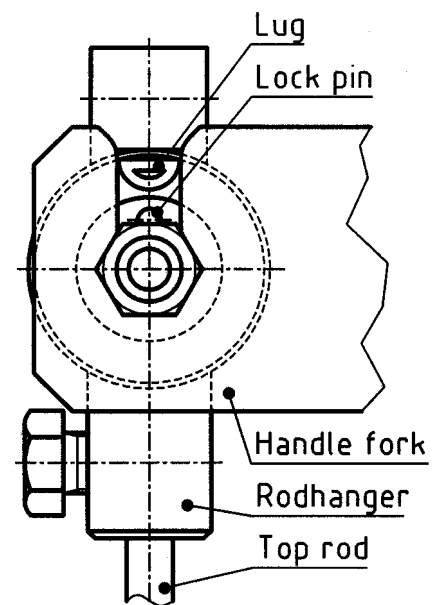

6.2.23 If additional adjustments of lugs and pins are required during insertion into the slots of the handle front, please take care of your fingers.

6.2.24 Push down the handle to its lowest position and remove the spanner handle from the lug of the rodhanger assembly.

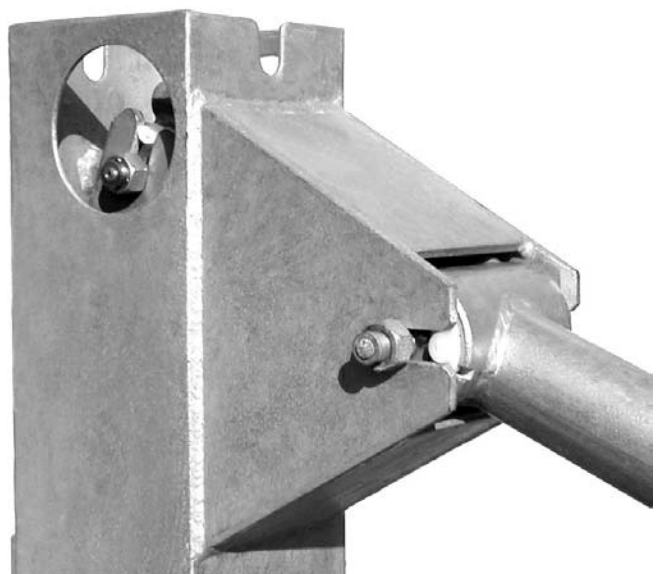

6.2.25 Prior to fastening the nuts of the fulcrum- and hanger pin, make sure that they are in correct position. Tighten nuts securely.

6.2.26 Insert the handle rear assembly into the handle front assembly as such that the handle is balanced correctly (remains in horizontal position). Tighten adjustment bolt securely.

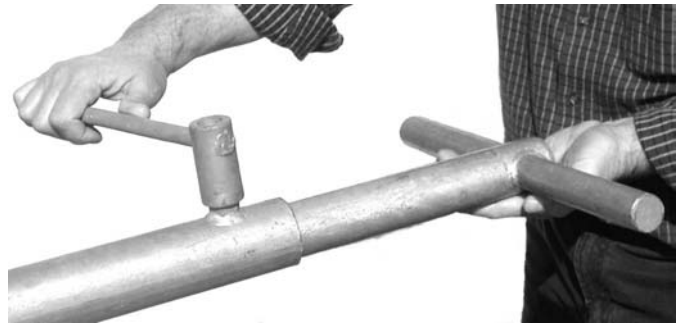

6.2.27 Operate the handle till the water flows out of the spout. The number of strokes required until full flow is reached, is determined by the installation depth of the cylinder (the installation depth divided by the maximal handle stroke indicates approximately the number of full strokes required). Due to the slightly bigger diameter of the riser pipes, **about six full strokes** are required for **lifting the water by 1 m**.

6.2.28 Initially the first water might be turbid and smelling from chorine, but after 15 to 30 minutes of operation it should become clear.

6.2.29 Now the following checks should be carried out:

- a) all nuts and bolts are well secured,
- b) effort required to operate the pump is normal,
- c) no leakage in the rising main (wait for 5 minutes to see whether water in the rising main assembly is receding,
- d) water discharge (approx. 40 strokes per minute) is above 16 litres,
- e) existence of identification mark of the support agency (painted or stamped).

6.2.30 Fill in the installation card (see Annex 5a). A copy of the card should be given to the users committee or to the handpump caretaker.

6.2.31 Fix the cover and tighten the cover bolt.

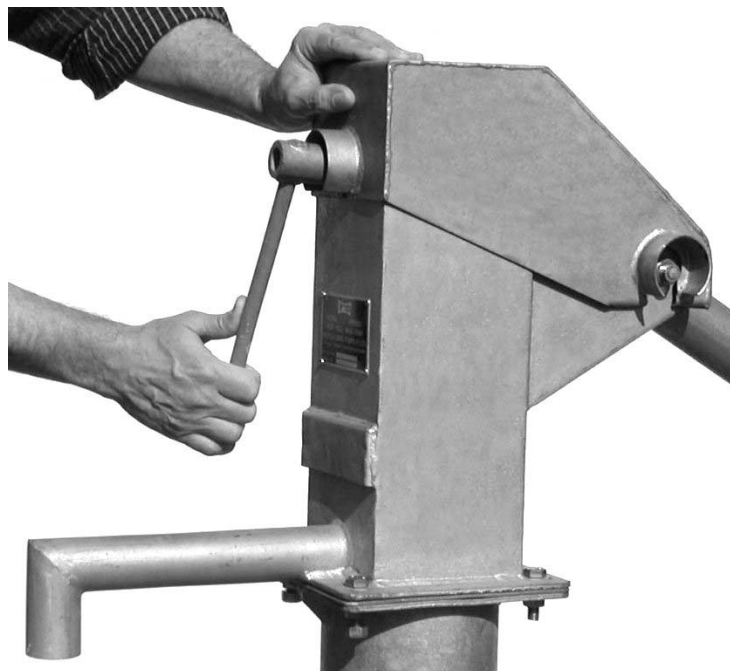

6.2.32 Inform the caretakers and users to wait until the next day and then pump for approximately 30 minutes, to make sure that the bleaching powder solution is pumped out completely.

6.2.33 Check whether caretakers or users are aware of the preventive maintenance required.

6.2.34 Check whether caretakers or users are informed where to get spare parts and whom to contact, if the pump needs repair.

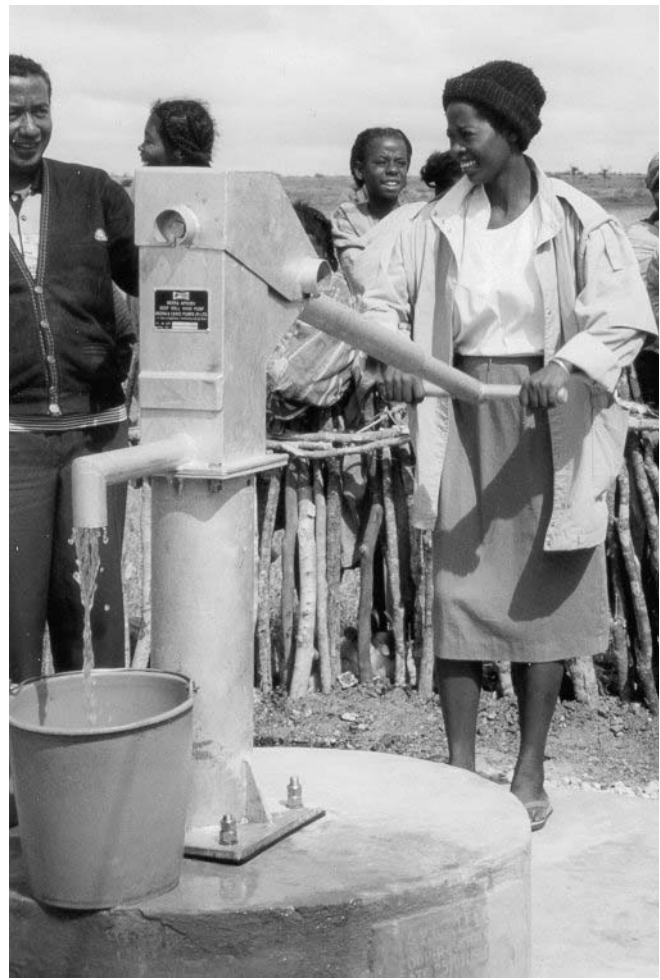

Part 2 Maintenance of the Afridev Handpump

7.0 Preventive Maintenance

Every pump owner, caretaker or the user committee is responsible for the preventive maintenance of the water point (handpump including surrounding) and therefore is entitled to receive regular training from the supplier of the handpump.

Preventive maintenance means regular check-up of the handpump at a fixed time interval and changing of spare parts before they are fully worn.

As an example; if the estimated lifetime of a plunger seal is one year, the plunger seal will be changed after a period of one year even if it is still functional. If during a preventive maintenance check, footvalve leakage is noticed, the caretaker will carry out repairs in the footvalve even though the pump has not broken down.

Such interventions help in preventing the sudden failure of the pump.

7.1 Preventive Maintenance Checks of Handpump

7.1.1 Weekly checks:

- Check that the flange bolts and nuts are tight.
- Check that the Fulcrum pin nuts and Hanger pin nuts are tight.

7.1.2 Tree monthly checks:

- Check if any fasteners or parts in the pump head are missing. If so, replace the parts.
- If any unusual noise is noticed, check reason for the same and take corrective actions.
- Check if the pump stand is shaky during operation. If yes, the stand is loose in the foundation and contamination of the well can take place. Take corrective measures to repair the foundation.
- Check if there is leakage in the pump. If more than 5 strokes are required before water comes out from the spout, it means the pump is leaking beyond an acceptable limit. This needs to be attended to. It may be necessary to replace bobbin / footvalve O-ring or attend to a leaking joint in the rising main. For attending to a defect in the rising main you may need the help of a skilled mechanic. The special leakage test can be conducted as described below.
- Carry out a "Leakage- and Discharge Test" (see 7.1.3 and 7.1.4 below).

7.1.3 Leakage test:

Testing shall start after a continuous flow of water through the spout has been obtained. The water shall then be collected in a container or bucket for 40 continuous full strokes of the plunger in one minute. Measure the quantity of water collected. Then allow the pump to rest for 30 minutes. Repeat the test and measure the discharge. The difference between the first and the second reading of discharge indicates leakage. If the difference is more than 2 litres, there is an un-acceptable leak and the cause should be investigated.

Another method is to count the number of strokes required before water comes out of the spout after the break of 30 minutes. If the number exceeds 5 strokes until water is flowing, it is an indication that there is an un-acceptable leak and the cause should be investigated.

Leakage mostly occurs because of worn bobbin or o-ring of the footvalve, disconnected rising main joints or perforated or cracked riser pipes.

7.1.4 Discharge test:

Testing shall start after a continuous flow of water through the spout has been obtained. The water shall then be collected in a container or bucket for 40 continuous full strokes of the plunger in approximately one minute. The water collected should be generally not less than 16 litres.

If the discharge is less than 10 litres for 40 strokes, there may be a need to change the bobbin or the u-seal/cup seal of the plunger or the bobbin or o-ring of the footvalve.

Another cause of a low discharge could be a perforated or cracked riser pipe or a disconnected pipe joint.

7.2 Maintenance of Pump Surrounding

Handpumps with platforms offer a good protection, because they seal off the well from external sources of contamination. However, even when handpumps are fitted, contaminations can still pollute the well through:

- a) cracked platforms and drainage channel,
- b) stagnant water near the well,
- c) animals (and human) excrements too close to the well (no fence),
- d) waste and other sources of contamination too close to the well.

It is the important task of the **Handpump Caretaker** to:

- 1.) check the platform for cracks and do the necessary repair,
- 2.) eliminate stagnant water by filling the dents and holes with earth,
- 3.) maintain the fence around the water point, so that no animals have access,
- 4.) keep the surroundings clean and tidy at all times,
- 5.) instruct the pump users how to use the pump and how to keep the pump surroundings clean.

(See also 4.1.2 Well siting and 4.1.3 Hygiene Education and Water Supply.)



8.0 Maintenance of Handpump

The handpump is like any other mechanical device and needs maintenance to keep it in good working condition. It has been observed that the maintenance in community handpumps is very often “Breakdown-based”.

In the absence of preventive maintenance, sudden breakdown of handpumps and disruption in water supply do occur. The danger of abrupt breakdown of the pump can be minimized if preventive maintenance is carried out.

The steps involved in maintenance are to:

- a) understand the cause for a problem and determine the remedy need,
- b) dismantle the pump as necessary,
- c) assemble the pump after replacing defective components,
- d) record details in the “Maintenance card” (see Annex V b).

8.1 Diagnosis of Handpump Problems

To identify the cause for a problem and remedy needed, please refer to the “Trouble Shooting Chart (Annex I.) This chart lists general operational problems, their causes and remedies.

8.2 Tools and Spare Parts required for Handpump Maintenance

8.2.1 The basic tools required for handpump maintenance are:

- a) Spanner for M16 hexagonal bolts and nuts (B2160),
- b) Fishing tool for retrieving of footvalve (B2150).

For deep installations (between 30 to 45 m) with a heavy load of the pumprod assembly, the use of Resting tool B2415 & Connecting tool B2420 is advisable (for threaded rods only).

8.2.2 The “List of Spare Parts for AFRIDEV Handpumps” is given in Annex II (see also “Replacement Interval of AFRIDEV Wearing Parts” in Annex III).

8.3 Procedure of Dismantling “Above Ground Components”

8.3.1 Loosen pump cover bolt and remove the cover.

8.3.2 Loosen hanger pin nuts and fulcrum pin nuts fully.

8.3.3 Move the pump handle to the lowest position and insert spanner handle into the rodhanger bush. Move the pump handle slowly upwards and guide the spanner handle into the two slots provided at the pump head.

8.3.4 As soon as the rodhanger is hanging freely, pull out the handle carefully (horizontal).

8.3.5 Remove the fulcrum pin and the bearing bush sets from the handle.

8.3.6 Remove the hanger pin and the bearing bush sets from the rodhanger.

8.3.7 Place all small components (fulcrum pin, hanger pin, bearing bushes etc.) inside the pump head cover to prevent that they get dirty.

8.4 Dismantling Threaded Pumprods

(including plunger and fishing of footvalve)

- 8.4.1 Take an additional pumprod and attach the connecting tool.
- 8.4.2 Pull out the top rod with rodhanger and disconnect the first joint.
- 8.4.3 Connect the additional pumprod with the connecting tool and lower the whole assembly slowly until the plunger rests on the footvalve.
- 8.4.4 Take the t-bar of the connecting tool and turn it clockwise for 3 complete revolutions.
- 8.4.5 The footvalve is now connected and the removal of the whole assembly can start.
- 8.4.6 Remove all pumprods "one by one" until the plunger rod with plunger and footvalve is released. Make sure that all rods are neatly placed near the pump and are in a clean place.

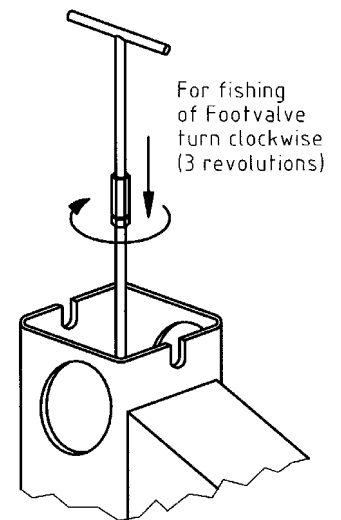

8.5 Re-installing Threaded Pumprods

(including placing of footvalve)

- 8.5.1 Attach the footvalve to the plunger (max. 3 revolutions) and connect plunger rod and all pumprods.
- 8.5.2 Instead of the top rod, connect an additional pumprod with the connecting tool.
- 8.5.3 After the footvalve is sitting firm in the conus of the footvalve receiver (cylinder), turn the t-handle of the connecting tool anti-clockwise for approximately 6 revolutions.
- 8.5.4 Lift the pumprod assembly as much that the additional pumprod and connecting tool can be replaced by the top rod and rod hanger.
- 8.5.5 Insert the spanner handle into the bush of the rodhanger and let the assembly rest in the two slots provided in the pump head.

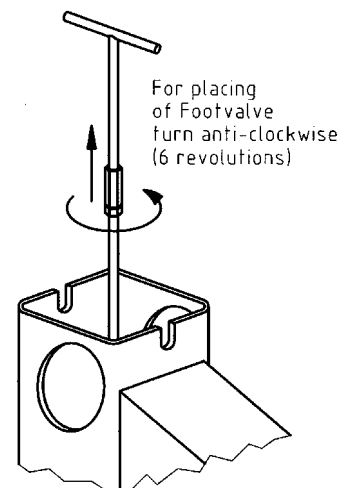

8.6 Dismantling Hook & Eye Pumprods

(including plunger and fishing of footvalve)

- 8.6.1 Pull out the top rod with rodhanger and disconnect the first joint.
- 8.6.2 Remove all pumprods "one by one" until the plunger rod with plunger is released.
- 8.6.3 Remove plunger rod and plunger from the last pumprod and replace them with the fishing tool.
- 8.6.4 Re-install all pumprods "one by one" until the fishing tool is resting on top of the footvalve.
- 8.6.5 Turn the pumprod assembly slightly so that the hook of the fishing tool connects with the footvalve assembly.
- 8.6.6 Remove all pumprods "one by one" until the rods with fishing tool and footvalve are released.
- 8.6.7 Make sure that all rods are neatly placed near the pump and are in a clean place.

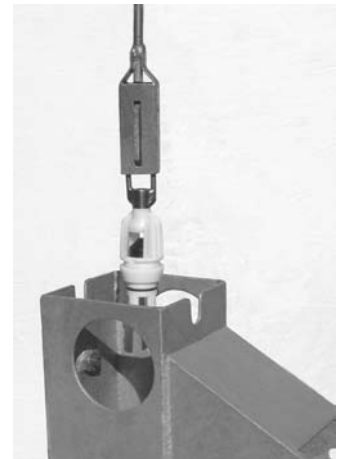
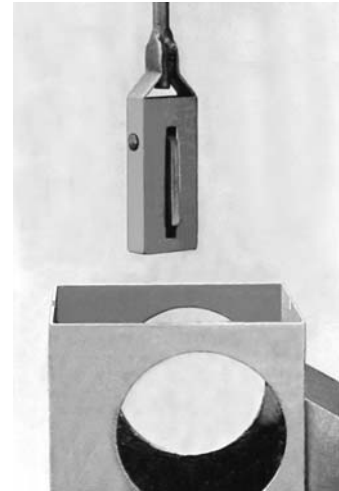

8.7 Re-installing Hook & Eye Pumprods

(including placing of footvalve)

- 8.7.1 Drop the plastic footvalve into the rising main pipe.
- 8.7.2 Re-install plunger, plunger rod and all pumprods.
- 8.7.3 Attach an additional pumprod with the connecting tool and push the footvalve gently in correct position.
- 8.7.4 Lift the pumprod assembly as much that the additional pumprod with connecting tool can be replaced by the top rod and rod hanger.
- 8.7.5 Insert the spanner handle into the bush of the rodhanger and let the assembly rest in the two slots provided in the pump head.

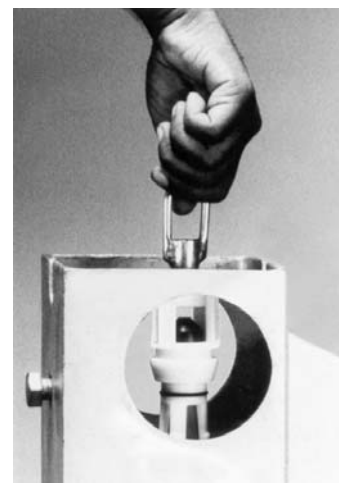

8.8 Dismantling and Re-installing FRP Pumprods

(including plunger and fishing of footvalve)

- 8.8.1 The advantage of FRP pumprods (FRP = Fibre Reinforced Plastic) is that once installed, the whole pumprod assembly can be pulled out of the rising main, without disconnecting the single rods. Therefore the time for retrieving of a pumprod assembly is a matter of 1 or 2 minutes.

Since the total weight of an pumprod assembly with FRP pumprods is roughly only 1/3 of the weight of a pumprod assembly of steel, removal of the assembly is very easy.



- 8.8.2 The procedure for retrieving and placing of the footvalve depends on the set-up of the plunger and footvalve (see also pages 47 and 48).

8.9 Re-assembling “Above Ground Components”

- 8.9.1 Place fulcrum pin with bearing bushes in the fulcrum bush.
- 8.9.2 Align the lock pins and the lugs of the bearing bushes and insert handle assembly into the pump head. Tighten the hexagonal nuts by hand.
- 8.9.3 Keep pump handle horizontal and place hanger pin with bearing bushes in rodhanger assembly.
- 8.9.4 Align the lock pins and the lugs of the bearing bushes and move the t-bar of the handle assembly slowly downwards, so that the rodhanger pin ends are slipping into the slots of the handle forks. Tighten the hexagonal nuts by hand.
- 8.9.5 Press the handle assembly to its lowest position and release the spanner from the bush on top of the rodhanger assembly.
- 8.9.6 Tighten the fulcrum pin- and rodhanger pin nuts securely with the spanner.
- 8.9.7 Operate the pump and check the discharge and leakage.
- 8.9.8 Attach the pump cover and secure it by tightening the cover bolt.

(For more information see also No. 6.3 of the installation part.)

9.0 Repair of Handpump

Major interventions such as the replacement of the rising main assembly or retrieving of dropped components are beyond the capacity of the handpump caretaker and therefore will need to be carried out by a skilled mechanic.

9.1 Removal of the Rising main

There are several reasons that makes it necessary to remove the rising main:

- an excessive leakage that cannot be attributed to a leaking footvalve (bobbin or o-ring),
- a disconnected riser pipe due to poor quality of the pipe joints,
- dropped components that have jammed inside the rising main and cannot be fished out,
- the cylinder is suspected to need replacement.

9.1.1 Cutting the Rising main

Traditionally when the rising main was removed it was cut into manageable lengths of 2 to 3 pipe lengths or 6 to 9 m (see picture).

Cutting of the rising main meant that a large number of joints had to be re-made upon replacement. If suitable double sockets were not available, joints were formed by warming the PVC-U pipes in a fire. It is very important that joints in the PVC-U rising main are correctly made to ensure a sustainable long-term repair (see also 4.4 Important Information for Jointing PVC-U Pipes).



9.1.2 Pulling out the whole Rising main

To minimise the number of joints that need to be made during a repair the rising main is removed from the borehole in one length without making any cuts. The problem is identified and repaired before replacing the rising main back in the borehole, once again in one length.

During removal of the rising main assembly in one length the joints will come under considerable stress. This procedure should only be attempted if it is known that the PVC-U joints were correctly made during the installation, otherwise there is a danger that a joint may break and could cause injury.

In addition to the tools needed for pump repair the additional resources needed to withdraw the rising main are:

- At least 8 people, preferably including all or some of the pump caretakers.
- Poles with forked ends for supporting the rising main when pulled out. The number of poles should be equal to the number of riser pipe lengths in the installation and their length should be approximately 3.5 to 4m.
- A guide rope of at least 10 m length, which is connected to the steel cone and is used for leading the tilting rising main into the right direction
- A cleared area is required next to the well, long enough to accommodate the complete rising main when laid down immediately after withdrawal. In this place, no disturbance should take place during the repair and the curing time of the new joints (12 hours).

The procedure is:

a.) Remove the footvalve. This may not be possible if there are components stuck inside the rising main. It is still possible to remove the rising main in one piece but extra care must be taken as the weight of water and components will make the control of the rising main as it comes out of the borehole much more difficult.

b.) Remove the pump head.

c.) Tie the guide rope to the cone plate.

d.) Start to pull the rising main out of the borehole by pulling the two ends of the support rope and the pipe. The guide rope is used to control the free end of the pipe. As the rising main comes out of the borehole start to bend it in the direction chosen for it to be laid down. Using the shorter forked poles to start to take the weight of the pipes at the same time to keeping the radius of the bend as long as possible.



e.) As the pipe continues to be pulled out the longer forked poles are used to support the free end of the pipe which should be kept up and the pipe horizontal so that the bend is at least three pipes long. If it has not been possible to remove the footvalve the open end of the pipe should be lowered just enough to drain the water out so that the weight is reduced. The shorter poles at the borehole end of the pipe need to be held off the ground to allow them to be moved easily along the line of removal. The longer poles in the middle and free end can be allowed to rest on the ground to take the weight and stabilise the pipe.



f.) If at any time a joint appears to be weak (e.g. there is evidence of burning as in a home made joint) the pipe should be carefully supported and cut at the suspect joint. **Do not try to bend a weak joint.**

g.) When the cylinder and suction pipe are reached they are carefully withdrawn, making sure to maintain control of the whole pipe. The whole pipe length can now be laid down.

h.) After the necessary repairs have been carried out the whole length of pipe must be carefully cleaned before replacement. Before replacing the Rising main pipe the borehole should be disinfected as described under 3.9 (Disinfecting the Well).

i.) Replacing the pipe is the reversal of removal. Some difficulty may be experienced inserting the cylinder and suction pipe, as some force has to be applied to bend the Rising main pipe sufficiently to enter the borehole.

Under normal circumstances, the preparation time for the procedure described above will take approximately one hour. After that, the time for withdrawal will take between 15 to 30 minutes and the time for the replacement of the rising main assembly should take not longer than 10 to 20 minutes.

If a number of pumprods are stuck inside the rising main (broken “hook & eye components) and all fishing attempts to retrieve them have failed, it is advisable not to withdraw the rising main in one piece. It is better to use the method described under 8.1.1 (Cutting the Rising main).

A different system for supporting the withdrawn rising main pipe is shown in the picture beside. Heavy logs are placed in the ground and are acting as a scaffolding, strong enough to accommodate one person. The support for the withdrawn rising main pipe is made by the persons on the scaffoldings and in the trees nearby.



9.2 Repair of the Rising main pipe

Whatever intervention is made, it is most important that **the overall length of the rising main pipe must not be changed**. Any change in the length of the rising main pipe would automatically affect the exact position of the plunger in the pump cylinder.

Unless an obstruction can be removed by tipping the pipe up, which is very unlikely, or there is leakage from a joint that can be reconnected, it will be necessary to cut the rising main and repair it with a socket.

9.2.1 Repair with Double Socket

The choice of where to cut depends upon the repair that needs to be carried out. If there is a hole in the pipe, which may be caused by the internal rubbing of a rod joint (due to a missing rod centraliser), the pipe will need to be cut in two places one on each side of the hole.

For this purpose a “Repair piece” with bell-ends at both sides will be needed, see sketch beside. (the technical drawing for manufacturing repair sockets can be found in Annex VII.)

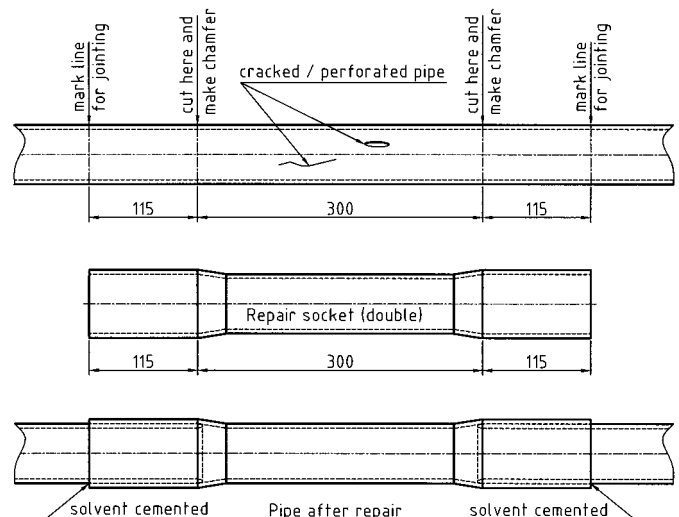

Cut the affected portion in such a way, that the total length of the rising main remains the same after jointing the repair piece.

9.2.2 Repair with Single Socket

If the problem only requires access to the inside of the rising main or cylinder, such as the removal of an obstruction, then the pipe only needs to be cut in one place. The location of the cut depends upon the problem to be resolved.

A single socket is a straight piece of pipe 230 mm long with an internal diameter that just fits over the outside of the rising main pipe (see drawing C2438 in Annex VII). Each end of the pipe at the joint must be marked at 115 mm to ensure that the single socket is equally distributed over the joint. The jointing of PVC pipe should be done as recommended in 5.4 (Important Information for Jointing PVC-U Pipes).

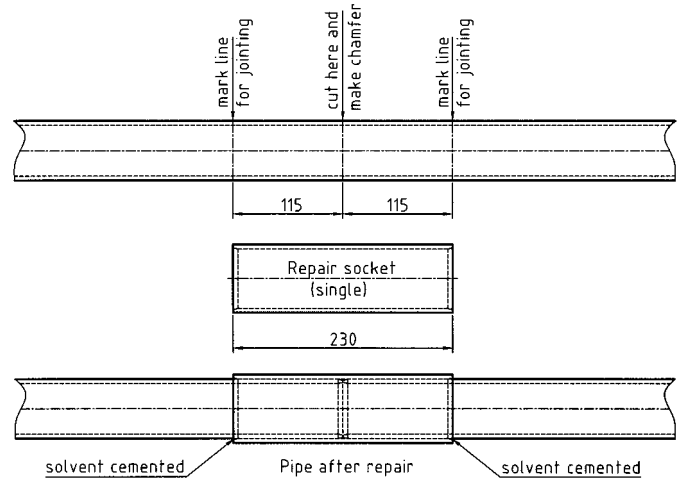

If a length of pipe has had to be cut out, for example it has a hole in it, it must be replaced by a pipe of equal length and two single socket joints made. The shortest length of a repair should be 300 mm to ensure that the joints on each side are adequate. Do not be tempted to make a patch with a piece of pipe and stick it on using solvent cement. It will not last and the rod centraliser will be quickly damaged as it rubs past the inside of the hole.

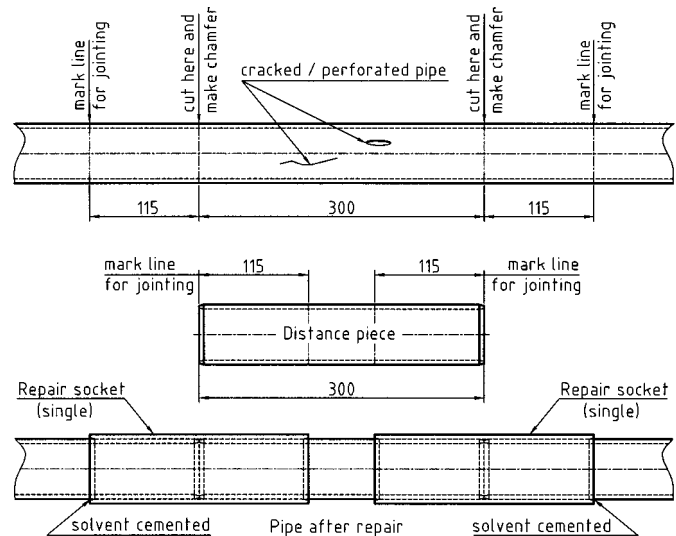

After the rising main pipe is back in the borehole, the exact lengths of the pumprod needs to be checked and adjusted as required (see also 5.2.11). The reason for checking the equal lengths of pumprod and rising main, is because this length is important for the exact position of the plunger inside the pump cylinder.

If the pumprod assembly is too long or too short compared to the rising main pipe, the plunger will either leave the plunger sleeve or hit the footvalve at every stroke during the operation of the pump. In both cases the plunger or the footvalve will be destroyed over a very short period of time.

9.3 Fishing of Dropped Handpump Parts

During installation or maintenance activities, handpump components might fall into the well causing an obstruction, which immobilises the pump.

Retrieving dropped components like a rising main from a **Dugwell** is not a problem, whereas fishing of dropped parts in a casing pipe of a **Borehole** can be a difficult and time consuming task.

In some cases, items inside the **Rising main pipe** may be extracted by removing the whole rising main and cutting it to gain access to the obstruction (as described under 8.2.2).

In other cases something relatively simple can be made by the Area Mechanic to suit the object causing the obstruction.

For example a “u-seal” that has rolled off the plunger and is left in the cylinder or rising main may be fished using a simple wire hook on a string. In the case of a “u-seal” left inside the rising main it is important not to try to fish the footvalve. If this is attempted the “u-seal” often causes the footvalve to jam inside the rising main pipe, making it necessary to remove the whole rising main assembly with the rods inside. Some ingenuity is required on the part of the Area Mechanic to deal with each situation as it arises.

A number of special tools “Fishing Tools” have been developed, in order to assist any fishing attempts of dropped handpump components. However, often these tools are not available or do not quite fit the problem at hand so more informal solutions need to be found. This mostly depends upon the ingenuity of the Area Mechanic.

The assembly drawings of the “Fishing tools” can be found in Annex VI.

Detail drawings for manufacturing of the developed fishing tools are available on request.

10.0 Recording of any Intervention

It is advisable to collect and record any data of a well, starting from digging or drilling, platform construction, installation of a handpump including all maintenance and repair interventions during the lifetime of the handpump and the well (like a “log-book” on a ship).

Besides **Installation and Monitoring** details, make the necessary entries of **Maintenance and Repair** in the documents of each pump. The information to be recorded will include date of breakdown, date of repair, nature of complaint, parts replaced and kind of repair or any other important observations. (see also “Examples for Recording of any Intervention” in Annex V).

Annex I

Trouble Shooting Chart for AFRIDEV Handpumps

Trouble Shooting Chart		Afridev Handpump Maintenance	
Problem	Operation	Cause	Remarks
No water	Handle operation is easy	Pumprods are disconnected	Pull out all Pumprods and replace broken and corroded rods
	Handle operation is difficult	Riser pipe is disconnected	Pull out complete Rising main, repair/replace pipes (solvent cement joints)
	Handle operation is normal	Cup seal is defect	Replace seal
		Borehole is clogged (silt or sand)	Rehabilitation of borehole (cleaning with compressed air or by bailing)
		Water level dropped below cylinder	Add Riser pipes and Pumprods
Delayed flow of Water	Handle operation is normal	Leaking of valve Bobbins	Check and replace Bobbins (Plunger and Footvalve)
		Leaking of Footvalve O-ring	Replace O-ring
		Leakage in pipe joints or	Pull out complete Rising main, repair/replace pipes (solvent cement joints)
		Rising main pipe is perforated	
Reduced discharge	Handle operation is difficult	Cup seal is too tight	Replace with seal of correct size
	Handle operation is normal	Full stroke is not possible	Check and adjust length of the Top rod
		Cup seal is worn	Replace seal
		Leaking of valve Bobbins	Check and replace Bobbins (Plunger and Footvalves)
		Leaking of the cylinder (cracked)	Pull complete Rising main, repair/replace cylinder (solvent cement joints)
Abnormal noise during operation	Handle operation is normal	Pumprods rubbing on Riser pipes	Check and replace worn Pumprod Centralisers
		Pumprod centralisers worn	Check and straighten bent Pumprods, replace worn Pumprod Centralisers
	Handle operation is inconvenient	Pumprods are touching Riser pipes	Straighten or replace bent Pumprods, replace worn Pumprod Centralisers
		Bearings are worn, Handle fork touching the sides of Pump head	Check and replace Bearing sets (4 off)
Pump handle shaky	Handle is shaky when operated	Bearings are worn	Check and replace Bearing sets (4 off)
		Fulcrum pin is loose	Check Fulcrum pin (and Bearing sets) and tighten both nuts fully
	Pump head is shaking	Hanger pin is loose	Check Hanger pin (and Bearing sets) and tighten both nuts fully
		Flanges are loose	Tighten all bolts and nuts of the flanges
	Pumpstand is shaking	Pump platform is cracked	Repair Pump platform or Well cover (for dugwells)

Annex II

List of Spare Parts for AFRIDEV Handpumps



Spare Parts List for AFRIDEV Handpumps

Note: all options are included

Drawing Number	Description of spare part	Unit Price US \$
Pump head		
B2003	Pump head assembly, Spout length 580 mm (welded and hot dip galvanized)	
B2003	Pump head assembly, Spout length 300 mm (welded and hot dip galvanized)	
B2036	Cover assembly (welded and hot dip galvanized)	
C1017	Hexagonal bolt M12 x 40, (for Pump head)	
C1016	Hexagonal nut M12 (for Pump head)	
Pump handle		
A2012	Handle assembly (Handle front B2013, Handle rear B2020 and Hexagonal bolt C1025)	
B2013	Handle front assembly (welded and hot dip galvanized)	
B2020	Handle rear assembly (welded and hot dip galvanized)	
C1025	Hexagonal bolt M16 x 25 (for adjustment of Handle rear assembly B2020)	
B2028	Rodhanger assembly (welded and hot dip galvanized)	
C1105	Hexagonal bolt M16 x 16 (for fastening of Top rod assemblies B2207, B2210, B2111 and C2113)	
B2024	Fulcrum pin assembly (Fulcrum pin C2025, Sleeve C2026, Pin C1027, Hex. nut special C2027 & Washer C1028)	
B2033	Hanger pin assembly (Hanger pin C2034, Sleeve C2035, Pin C1027, Hexagonal nut C1018 and Washer C1028)	
C2044	Bearing bush outer (Polyacetal POM, for Fulcrum- and Hanger pins)	
C2045	Bearing bush inner (Polyamide PA 6.6, for Fulcrum- and Hanger pins)	
Pump stand		
B2050	Stand assembly (with Legs, welded and hot dip galvanized)	
B2221	Stand assembly (with Bottom flange, welded and hot dip galvanized)	
C2059	Gasket (Rubber, for Stand assembly B2221)	
B2083	Anchor assembly (welded, with Hexagonal nuts C1130 and Washers C1069, used for Stand assembly B2221)	
C1130	Hexagonal nut (Brass, M16, for Anchor assembly)	
C1069	Washer (Brass, M16, for Anchor assembly)	
Pumprods		
B2207	Top rod assembly (Mild Steel, threaded version, welded and hot dip galvanized)	
B2214	Pumprod assembly (Mild Steel, threaded version, welded and hot dip galvanized)	
C2212	Centraliser (Nitrile rubber, for threaded and FRP Pumprods)	
B2210	Top rod assembly (Stainless Steel, threaded version)	
B2216	Pumprod assembly (Stainless Steel, threaded version)	
B2258	Plunger rod assembly (Stainless Steel, threaded version)	
A5896	Pumprod connector (for FRP Pumprods)	
A5890	Plunger rod connector (for FRP Pumprods)	
C5894	FRP Pumprod (Polyester resin, pultruded, 60-70% Glass fibres)	
B2111	Top rod assembly (Stainless Steel, Hook & Eye version)	
B2114	Pumprod assembly (Stainless Steel, Hook & Eye version)	
B2116	Plunger rod assembly (Stainless Steel, Hook & Eye version)	
C2109	Centraliser (Nitrile rubber, for Hook & Eye version)	
Rising main		
B2106	Riser pipe assembly (PVC-U, Riser pipe C2129 solvent cemented with Socket C2261)	
C2046	Riser pipe (PVC-U, Riser pipe with Bell ends)	
C2261	Socket (PVC-U, for Riser pipes C2046 and Cylinder assembly B2297)	
C2042	Top sleeve (PVC-U, for holding all Rising main assemblies)	
C2043	Flapper (Rubber, for covering the opening of the Rising main at the top)	
C2076	Centraliser 6" (Nitrile rubber, for 4" casings)	
C2077	Centraliser 5" (Nitrile rubber, for 6" casings)	
C2078	Centraliser 4.5" (Nitrile rubber, for 5" casings)	
C2079	Centraliser 4" (Nitrile rubber, for 4" casings)	
C1087	Rope (Polypropylene PP, Polyethylene PE or Poliamide PA, twisted or woven)	

Annex III

Replacement Interval of AFRIDEV Wearing Parts



Replacement Intervals of AFRIDEV Wearing Parts

Drawing Number	Description of spare part	Qty per pump	Approximate Lifetime	Recommended Replacement Interval
Pump head with Pump handle				
B2024	Fulcrum pin assembly (Fulcrum pin C2025, Sleeve C2026, Pin C1027, Hexagonal nut C1018, Washer C1028)	1	5 to 8 years	replace as required
B2033	Hanger pin assembly (Hanger pin C2034, Sleeve C2035, Pin C1027, Hexagonal nut special C2027, Washer C1028)	1	5 to 8 years	replace as required
B2028	Rodhanger assembly (Hanger bush C2029, Connector C2030, Retainer bush C2031, Sleeve C2032, Hexagonal bolt C1105)	1	5 to 8 years	replace as required
C2044	Bearing bush outer (Polyacetal, injection mouldeded)	4	1 to 2 years	every year
C2045	Bearing bush inner (Polyamide, injection mouldeded)	4	1 to 2 years	every year
Pumprods				
B2207	Toprod assembly (Mild Steel rods, with hexagonal coupler)	1	3 to 5 years	replace as required
B2214	Pumprod assembly (Mild Steel rods, with hexagonal couplers)	1 to 15	3 to 5 years	replace as required
C2212	Centraliser (Nitrile Rubber, for threaded Pumprods and FRP Rods)	1 to 15	2 to 3 years	every second year
C2109	Centraliser (Nitrile Rubber, for Pumprods with Hook & Eye connectors)	1 to 15	2 to 3 years	every second year
Rising main				
B2106	Riser pipe assembly (PVC-U, Riser pipe C2129 with Socket C2261)	1 to 15	3 to 5 years	replace as required
C2046	Riser pipe (PVC-U, Riser pipe with Bell-end)	1 to 15	3 to 5 years	replace as required
C2042	Top sleeve (PVC-U)	1	3 to 5 years	replace as required
C2043	Flapper (HDPE or Rubber,)	1	3 to 5 years	replace as required
C2076	Centraliser 6" (Rubber, for 6" casings)	2 to 15	3 to 5 years	replace as required
C2077	Centraliser 5" (Rubber, for 5" casings)	2 to 15	3 to 5 years	replace as required
C2078	Centraliser 4.5" (Rubber, for 4.5" casings)	2 to 15	3 to 5 years	replace as required
C2079	Centraliser 4" (Rubber, for 4" casings)	2 to 15	3 to 5 years	replace as required
Pump Cylinder				
B2297	Cylinder assembly (PVC-U Cylinder C2072, Socket C2261, Suction pipe C2262, Brass Footv. receiver C2299, Brass Liner C2073, O-Ring C1020)	1	5 to 8 years	replace as required
B2071	Cylinder assembly (PVC-U Cylinder C2072, Reducer C2080, Suction pipe C2081, POM Footvalve receiver C2074, Brass Liner C2073, O-Ring C1020)	1	5 to 8 years	replace as required
Plunger and Footvalve				
B2085	Valve body assembly (C2086/87 spinwelded, POM Plunger & Footvalve)	1 to 2	3 to 5 years	replace as required
C1011	O-Ring (Nitrile rubber, for Brass Footvalve A2298)	1	2 to 3 years	every second year
C2088	Bobbin (Nitrile rubber, for all Plunger & Footvalve types)	2	2 to 3 years	every second year
C2758	Cup seal (Nitrile rubber, for Brass Plunger A2266)	1	2 to 3 years	every second year
C1021	O-Ring (Nitrile rubber, for Plastic Footvalve A2096 or A2265)	1	2 to 3 years	every second year
Other parts				
C2059	Gasket (Rubber, for Stand assembly B2055)	1	5 to 8 years	replace as required
C2095	Compression cone (Rubber, for holding the Rising main pipe)	1	5 to 8 years	replace as required

Note:

The expected lifetime of the AFRIDEV Handpump is between 10 to 15 years. However, the lifetime of such technical equipment is determined by many factors:

- a) Pump material and/or workmanship not as per specification,
- b) Inadequate preventive maintenance or no maintenance,
- c) Pump damage due to incorrect, excessive or abusive operation,
- d) Water quality (salinity, silt or sand etc.),
- e) Climatic and environmental conditions,
- f) Poor finishing of the Borehole or wrong (poor) installation of the pump,
- g) any other possible irregularities.

Annex IV

Correct Storage of AFRIDEV Handpump Components

Correct Storage of AFRIDEV Handpump Components

In order to keep the Afridev Handpump components in good condition, special care has to be taken for storage of these spare parts. The Afridev Handpump components are made of different materials groups, like:

- a) Metal parts and assemblies
- b) Rubber components
- c) Plastic components
- d) Chemical liquids

These specific material types require different storage conditions, which are described below.

Metal parts and assemblies

All **major assemblies** are treated against corrosion by “hot dip galvanizing”, which gives a good protection for hot and humid conditions. For storing these assemblies (Pump head, Cover, Handle Pump stands etc.), care should be taken that the corrosion protection (zinc) on the surfaces will not be scratched.

Electroplated components do not give a long lasting corrosion protection, therefore components like Fulcrum- and Hanger pins, Spanner, Bolts and Nuts etc., should be stored in a dry place.

Long and flexible components like all (metallic) Pumprods need to be stored on a flat surface, so that no bending takes place (bent rods are mostly the cause of perforated Riser pipes).

Stainless Steel components and **Brass components** do not require special storage conditions.

Rubber components

Nitrile and natural Rubber components are sensitive against “Ultra Violet Rays” and hot conditions. It is not allowed to store these materials in a place, where sunlight has access. The **flexible rubber components** like O-Rings, U-Seal, Cup seals, Bobbin Pumprod centralisers etc. should be kept in a safe place, so that no heavy materials can be placed on top of them. Rubber components that are badly bent or squashed for a long time (in a hot place) will not be able to recover and therefore cannot be used anymore.

Thick walled rubber components like Compression cone or Rising main Centralisers are not so critical products for storage.

Special care has to be taken that rubber products are not stored in places where chemical substances are kept (also Oil can be harmful).

Plastic components

Plastic components, like rubber products have a very low resistance against “Ultra Violet Rays”.

Especially PVC-U pipes are getting brittle when stored in the sunlight and cracking of Riser pipes are mostly the cause of wrong storage.

Hot storing places are also not recommendable, whereas humid places are not harmful.

Components like Bearing bushes and Footvalve receivers are not critical products for storage, apart from direct sunlight.

Special care has to be taken for correct placing of Riser pipes (especially pipes with bell ends). Besides a flat place, a careful stacking is required and the stack is not allowed to be too high, because the heavy weight will squash the lowest pipes (see picture as an example for good stacking).

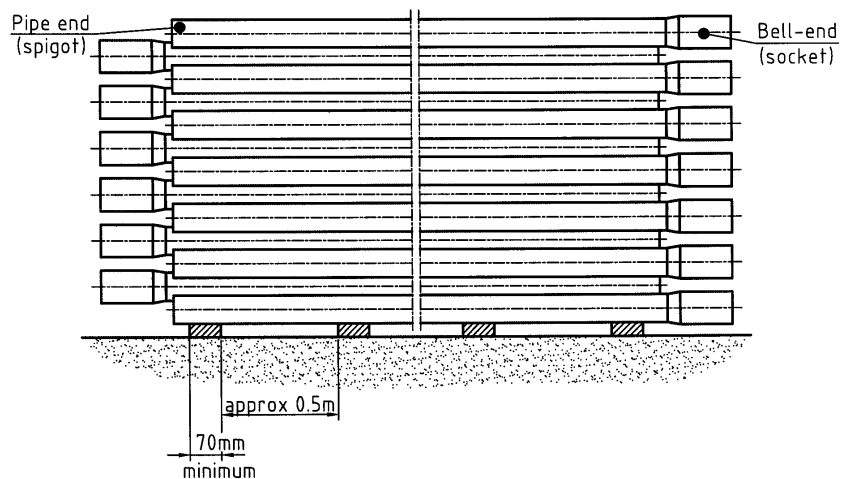

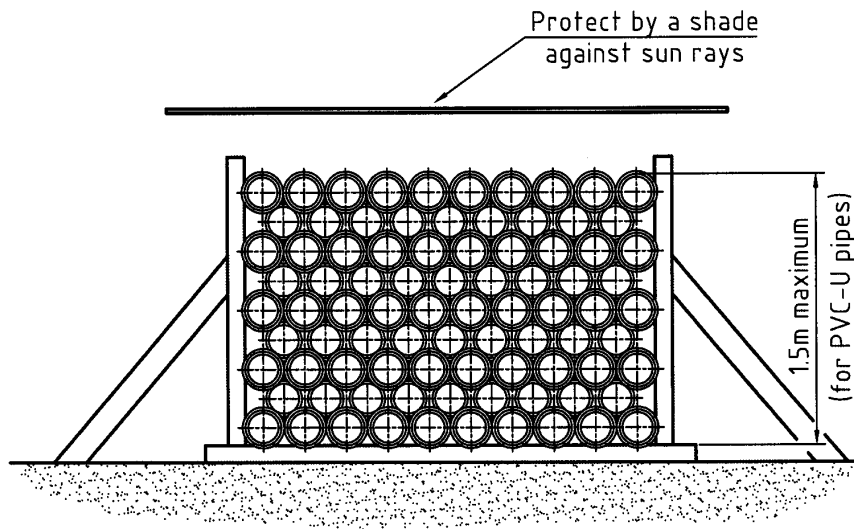

Chemical substances

Cleaning fluid and **Solvent cement** for jointing Rising main pipes should not be stored in large quantities. It is advisable to procure solvent cement locally, shortly before pump installation takes place. These substances should be kept in a cool and dry place, which is in most stores not available. Since the solvent cement keeps its liquidity only for a short period of time, never procure large quantities (for financial reasons). As soon as the solvent cement is not running smoothly it is not fit anymore to make a good bonding of pipe joints (and should be disposed).

Annex V

Examples for Recording of any Intervention

- a) Installation Card
- b) Maintenance Card
- c) Monitoring Card



Installation Card

Handpump Installation	
Name of Project	
Project Organisation / Agency	
Date of installation	

Handpump location	
Village	
District	
Country	

Handpump details	
Supplier's Name	
Handpump Code No.	
Type of Handpump	
Type of Pump stand	

Borehole or Dugwell	
Name of Drilling Company	
When was hole or well completed	
Depth of borehole or dugwell	m
Static Water Level (SWL)	m
Depth of cylinder setting	m
Length of pedestal pipe (if any)	m
Diameter of well casing	mm

Pump Platform	
Type of Platform	
Spill water used for	

Cost of Waterpoint	
Cost of HP	US \$
Cost of dugwell	US \$
Cost of borehole	US \$
Cost of platform	US \$
Total costs for the whole set-up	US \$

Water users	
Number of pump users	Persons
Approximate consumption per day	litres
Users other than domestic	

Name of recording person	Date:	Signature:
--------------------------	-------	------------



Monitoring Card

Handpump owner		Handpump code No:
-----------------------	--	--------------------------

Handpump location	
Village	
District	
Country	

Monitoring Data									
HP is working	good	<input type="checkbox"/>	fair	<input type="checkbox"/>	bad	<input type="checkbox"/>			
Condition of HP surrounding	good	<input type="checkbox"/>	fair	<input type="checkbox"/>	bad	<input type="checkbox"/>			
Grouting of pedestal or pump stand	firm	<input type="checkbox"/>	loose	<input type="checkbox"/>					
No. of strokes to fill a 20-liter bucket	strokes								
Corrosion of pump stand and -head	none	<input type="checkbox"/>	slight	<input type="checkbox"/>	bad	<input type="checkbox"/>			
Corrosion of handle parts	none	<input type="checkbox"/>	slight	<input type="checkbox"/>	bad	<input type="checkbox"/>			
Condition of plunger set-up	good	<input type="checkbox"/>	fair	<input type="checkbox"/>	bad	<input type="checkbox"/>			
Condition of footvalve set-up	good	<input type="checkbox"/>	fair	<input type="checkbox"/>	bad	<input type="checkbox"/>			
Worn out sealing parts	Bobbins	<input type="checkbox"/>	O-Rings	<input type="checkbox"/>	Plunger seal	<input type="checkbox"/>			
Wear between rising main/pump rods	none	<input type="checkbox"/>	slight	<input type="checkbox"/>	bad	<input type="checkbox"/>			
Wear betw. rising main/centralisers	none	<input type="checkbox"/>	slight	<input type="checkbox"/>	bad	<input type="checkbox"/>			
Wear on cylinder liner	none	<input type="checkbox"/>	slight	<input type="checkbox"/>	bad	<input type="checkbox"/>			
Wear on bearing parts	none	<input type="checkbox"/>	slight	<input type="checkbox"/>	bad	<input type="checkbox"/>			
Is preventive maintenance done	good	<input type="checkbox"/>	fair	<input type="checkbox"/>	bad	<input type="checkbox"/>			
Why poor performance / breakdown	no spares	<input type="checkbox"/>	no funds	<input type="checkbox"/>	no skill	<input type="checkbox"/>	no mechanic	<input type="checkbox"/>	
No. of breakdowns	times								
Mean down time	days								
Costs of parts replaced	US\$								
Cost of labour	US\$								
Total costs	US\$								
Who carried out the repair									
Distance to nearest spare-part shop	km								
Is tech./ mech. assistance available	yes	<input type="checkbox"/>	no	<input type="checkbox"/>					
Is maintenance system satisfying	yes	<input type="checkbox"/>	no	<input type="checkbox"/>					
Is the pump caretaker trained	yes	<input type="checkbox"/>	no	<input type="checkbox"/>					
Is there a user committee	yes	<input type="checkbox"/>	no	<input type="checkbox"/>					

Name of Repairer	
-------------------------	--

Repair costs	
Cost of pump parts	US \$
Cost of repair	US \$
Total repair costs	US \$

Comments:		
Recording person	Date:	Signature:

Annex VI

Drawings of Fishing Tools for dropped Handpump Parts

- a) For Fishing disconnected Pumprods
- b) For Fishing broken Pumprods
- c) For Fishing disconnected or broken Riser Pipes

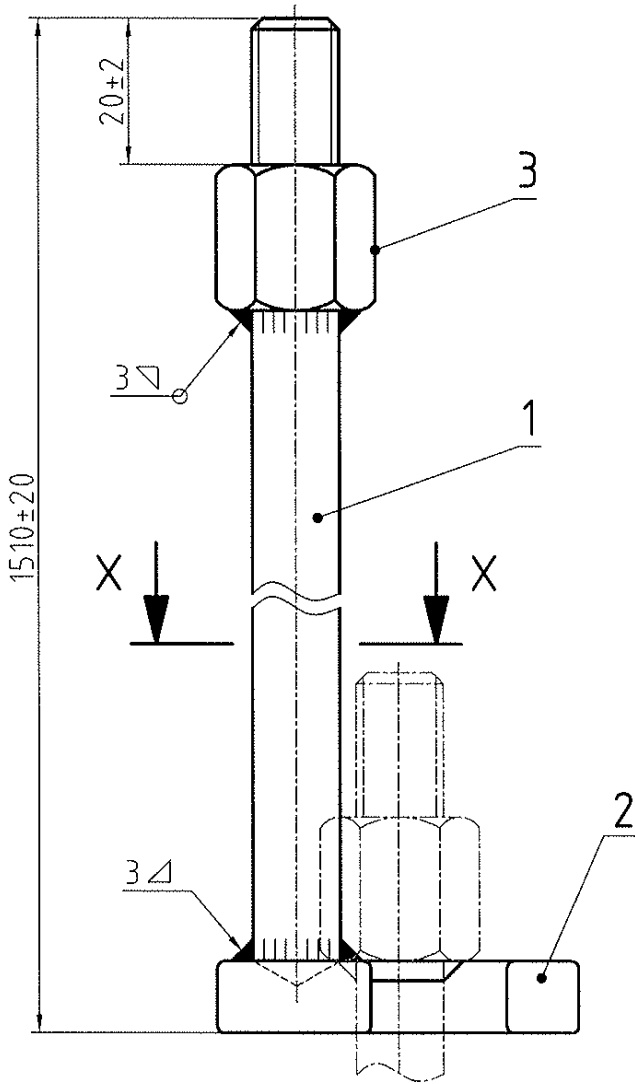

NOTE:
 THIS FISHING TOOL IS USED
 FOR FISHING DISCONNECTED
 PUMPRODS.
 (Ø12 mm THREADED RODS
 WITH HEX. COUPLER AND
 Ø10 mm RODS WITH EYE
 CONNECTOR).

FOR FISHING BROKEN RODS
 OF Ø10 OR 12 MM, USE
 FISHING TOOL B2427.

Section X-X

TURN CLOCKWISE
 FOR FISHING

DISCONNECTED PUMPROD

GENERAL TOLERANCE +/- 1 UNLESS OTHERWISE STATED

WELDED TO ISO 9692

3	1	Hex. coupler	C1012	---
2	1	Fishing hook	C2426	---
1	1	Rod	C2425	---
Pos.	Qty.	Description	Drawing. No.	Remarks

Rural Water Supply Network 	Sub assembly		Scale:	Drawn by:	K.Erpf	12.03.03	
	Fishing tool assy.			1:1	Checked by:		
					Released by:		

International Handpump Specification		B2424
--------------------------------------	--	-------

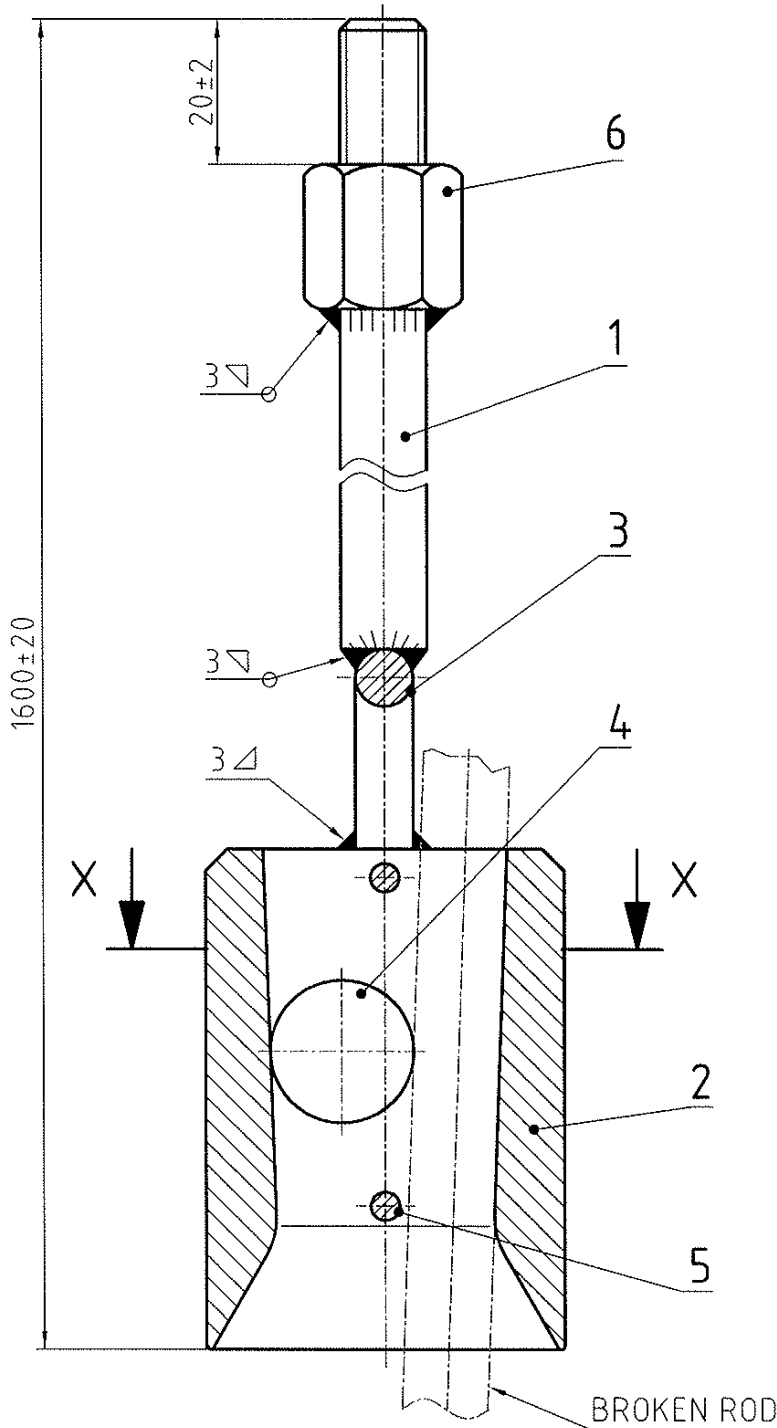

NOTE:
 THIS FISHING TOOL IS USED
 FOR FISHING BROKEN RODS.
 OF Ø12 mm.
 FOR RODS OF Ø10 mm, USE
 FISHING CONUS C2440

FOR FISHING DISCONNECTED
 PUMPRODS, USE FISHING
 TOOL B2424.

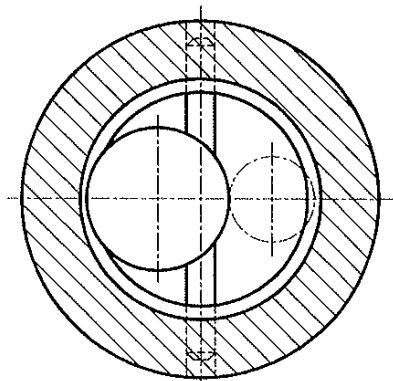

Section X-X

GENERAL TOLERANCE +/- 1 UNLESS OTHERWISE STATED

WELDED TO ISO 9692

6	1	Hex. coupler	C1012	---
5	2	Pin	C1135	---
4	1	Steel ball	C1134	---
3	1	Bracket	C2429	---
2	1	Fishing conus	C2428	(or C2440)
1	1	Rod	C2425	---
Pos.	Qty.	Description	Drawing. No.	Remarks

Rural Water Supply Network



Sub assembly

Fishing tool assy.

Scale:

1 : 1

Drawn by:

K.Erpf

13.03.03

Checked by:

Released by:

International Handpump Specification



B2427

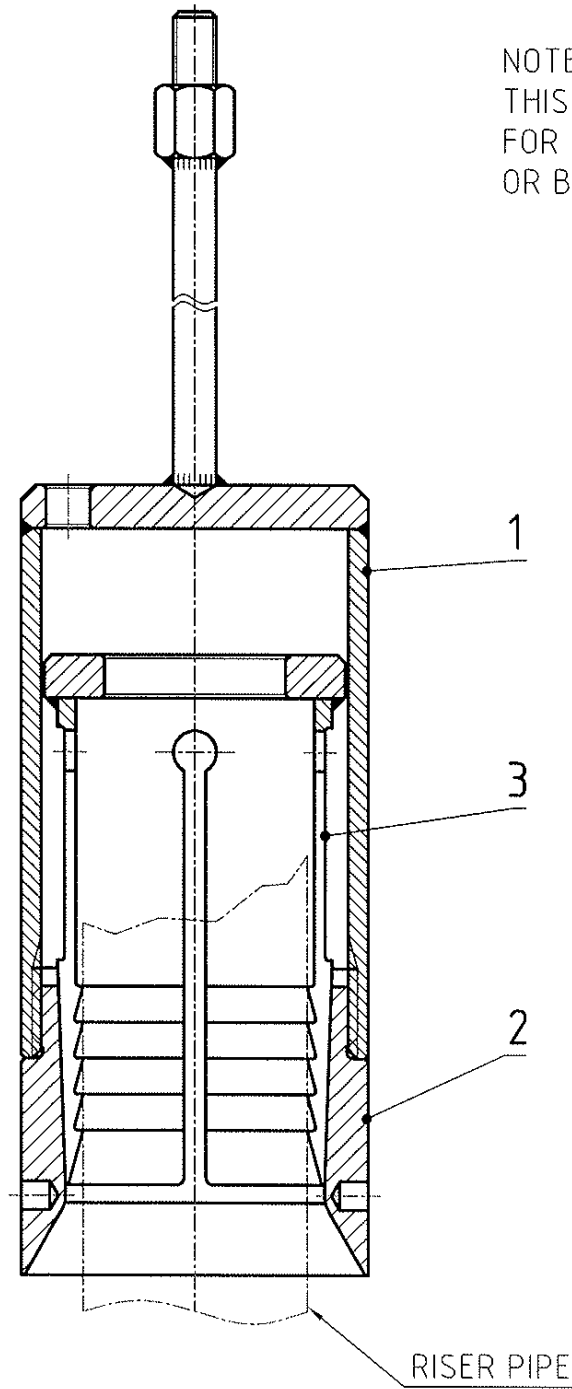

NOTE:
THIS FISHING TOOL IS USED
FOR FISHING DISCONNECTED
OR BROKEN RISER PIPES.

3	1	Collet assembly	B2435	---
2	1	Locating ring	C2434	---
1	1	Housing assembly	B2431	---
Pos.	Qty.	Description	Drawing. No.	Remarks

Rural Water Supply Network 	Sub assembly	Scale: 1 : 2	Drawn by:	K.Erpf	12.03.03
	Fishing tool assy.		Checked by:		
			Released by:		
International Handpump Specification			A2430		

Annex VII

Technical Drawings of Repair Sockets

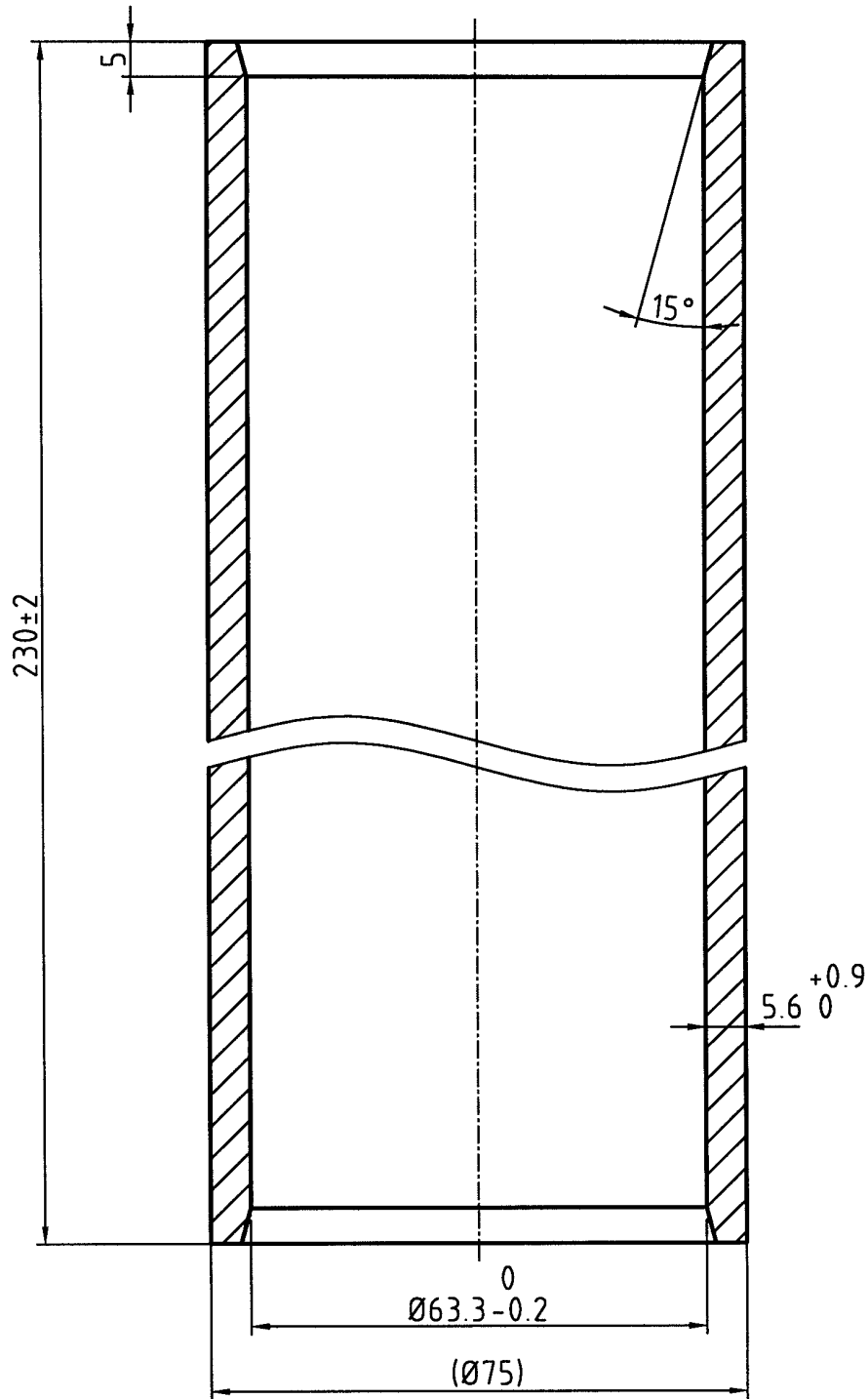

GENERAL TOLERANCE ± 0.1 UNLESS OTHERWISE STATED

ALL SHARP CORNERS TO BE ROUNDED OFF

Repair socket	$\text{Ø}75/5.6 \times 230$	PVC-U	ISO 4422-2/11922-1	Serie 6.3 / PN 16
Description	Dimensions	Material	Standards	Remarks
Rural Water Supply Network RWSN	Detail drawing		Scale: 1:1	Drawn by: K.Erpf 20.09.03
	Repair socket			Checked by: <i>[Signature]</i> 02.03.07
				Released by: <i>[Signature]</i> 07.03.07
International Handpump Specification				C2438

* THIS ANGLE CAN VARY BETWEEN 9 TO 20°

** BELL-ENDS TO BE MADE BY HEAT FORMING

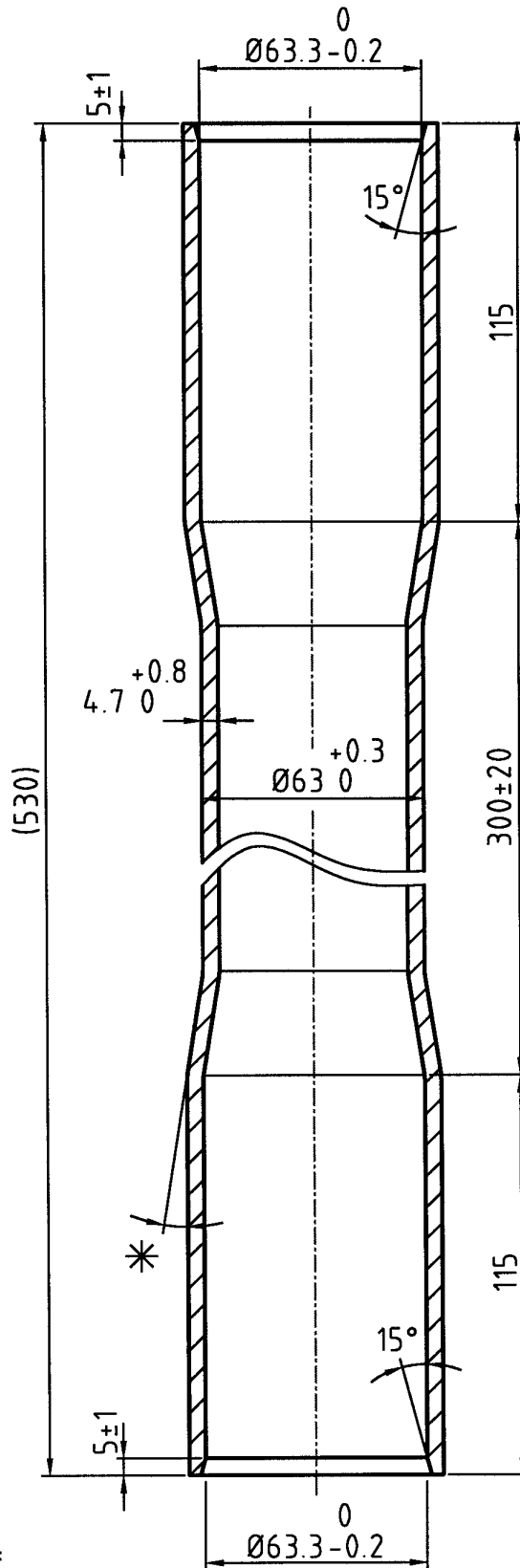

ALL SHARP CORNERS TO BE ROUNDED OFF
GENERAL TOLERANCE ± 0.2 UNLESS OTHERWISE STATED

Repair socket	$\text{Ø}63/4.7 \times 550$	PVC-U	ISO 4422-2/11922-1	Serie 6.3 / PN 16
Description	Dimensions	Material	Standards	Remarks
Rural Water Supply Network 	Detail drawing		Scale:	Drawn by: K.Erpf 13.11.02
	Repair socket		1 : 2	Checked by: 02.03.07
International Handpump Specification				Released by: 07.03.07
				C2439